

# DRY SYSTEMS TECHNOLOGIES®

8102 Lemont Road, Suite 700, Woodridge, Illinois 60517, USA  
Phone: 630-427-2051 \* Fax: 630-427-1036 \*

---

## Flame-Proof Alternator – MSHA Approved Model M500-521-01

---

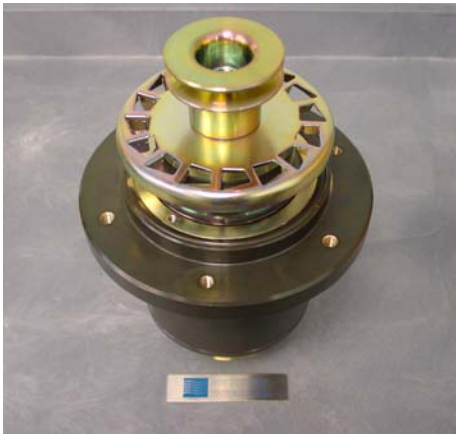
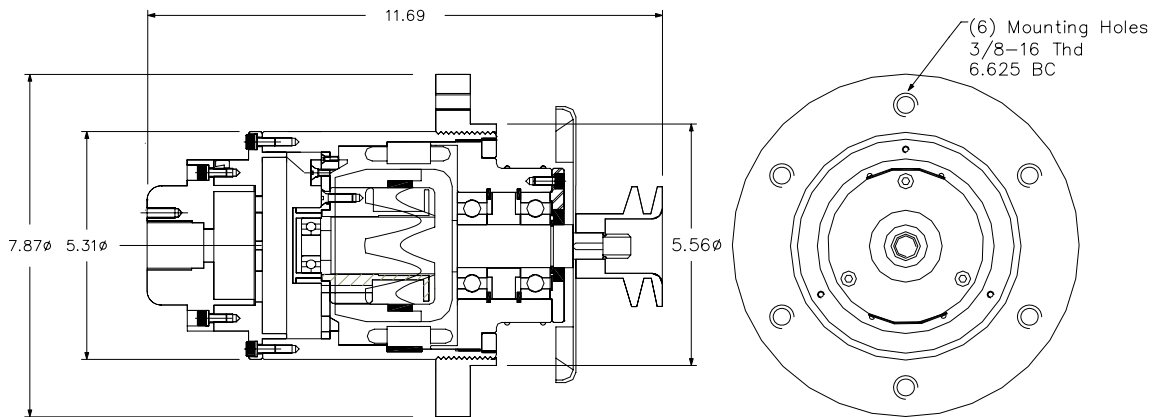

- 12 Volt – 25 Amps – 300 Watts
  - 24 Volt – 12.5 Amps – 300 Watts Available
  - Heavy-Duty Construction – six tapped holes for easy mounting
  - Internal Short Circuit Device - protects the alternator from overload.
  - Indicator Charge Pilot Light - will show the charging condition, indicates a properly functioning alternator
- 
- Self Exciting – no internal relays needed
  - Heavy-Duty Belt Drive - two sealed heavy-duty front bearings and one rear bearing allow for greater fan-belt torque. Bearings do not require greasing
  - Accepts 1 1/8" Packing Glands
  - Multiple Pulleys Available
  - Max RPM 12,000
  - MSHA Approval – 07-JA040001-0