

DRY SYSTEMS TECHNOLOGIES®

DRY SYSTEM® DIESEL POWER PACKAGE PERMISSIBILITY CHECKLIST M150-015-01

Page 1 of 11

**DST DRY SYSTEM®
MODEL M150
DIESEL POWER PACKAGE
MSHA 7F-021-0 APPROVED**

**116 HP ISUZU 6BG1-MAP DIESEL ENGINE
MSHA 7E-A006-0 APPROVED**

DRY SYSTEMS TECHNOLOGIES®
8102 Lemont Road, Suite 700
WOODRIDGE, IL 60517, USA
Phone: 630-427-2051 * Fax: 630-427-1036
E-mail: eng@drysystemstech.com

DO NOT CHANGE WITHOUT MSHA APPROVAL

REVISION 02 * DATED AUGUST 2004

Dry Systems Technologies®

8102 Lemont Road, Suite 700, Woodridge, Illinois 60517, USA
Phone: 630-427-2051 * Fax: 630-427-1036 * E-mail: eng@drysystemstech.com

M150-015-01 * PERMISSIBILITY CHECKLIST * Page 2

DST DRY SYSTEM® DIESEL POWER PACKAGE FOR 116 HP ISUZU 6BG1-MAP DIESEL ENGINE

Isuzu Diesel Engine

1. [] It has been determined that the area, in which tests are to be performed, is in [FRESH AIR](#).
2. [] The machine is equipped with a MSHA Part 7E, Category A Approved six cylinder [Isuzu Model 6BG1-MAP](#) naturally aspirated diesel engine.

DST Air Intake System

The **Air Intake System** of this **DST Model M150 Diesel Power Package** includes the following DST supplied components: An intake manifold, connecting pipes and elbows, an intake flame arrestor, an intake air shut-down valve with an actuating cylinder and mounting flanges, and an intake air cleaner.

Illustration 1 depicts the components of the intake system.

3. [] All components appear to be the same as shown on **Illustration No 1** of this Permissibility Checklist. There is no visible damage, cracks, or dents on the intake system.
[WEEKLY]

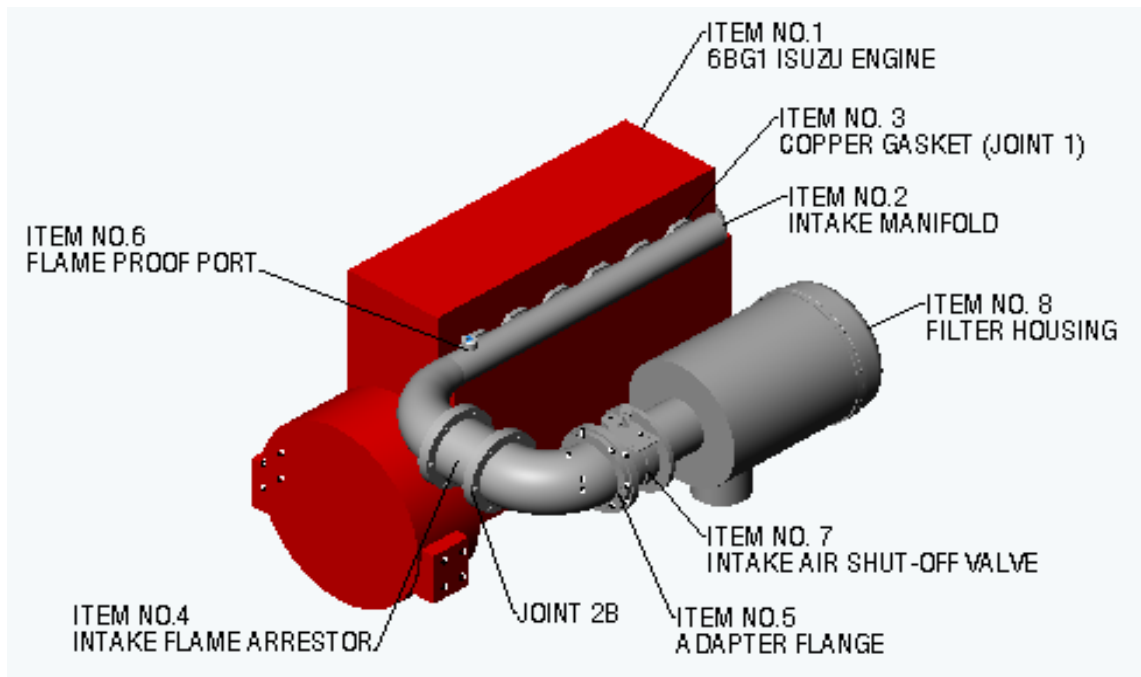

Illustration No 1: Air Intake System.

DO NOT CHANGE WITHOUT MSHA APPROVAL

REVISION DATE: 08-04

DRY SYSTEMS TECHNOLOGIES®

M150-015-01 * PERMISSIBILITY CHECKLIST * Page 3

DST DRY SYSTEM® DIESEL POWER PACKAGE FOR 116 HP ISUZU 6BG1-MAP DIESEL ENGINE

4. [] **Item No 2** is the intake manifold and intake pipe assembly. It is securely attached to the Isuzu engine and **Item No 3**, a copper gasket is installed on **Joint "1"** between the components. All fasteners and locking devices are in place and tight.
[WEEKLY]
5. [] A 0.0015" feeler gage cannot be inserted greater than 1/8" into the **Joint "1"**
[WEEKLY]
6. [] **Item No 4** is the intake flame arrestor. It is securely attached to the inlet flange of the intake pipe/manifold and all fasteners and locking devices are in place and tight. No gasket is installed on **Joint "2-A"** between the components.
[WEEKLY]
7. [] A 0.004" feeler gage cannot be inserted into the **Joint "2-A"**.
[WEEKLY]
8. [] Once every twelve month, remove the intake flame arrestor. The core of the flame arrestor consists of a 4.00" wide stainless steel crimped ribbon element. There is no apparent damage to the flame cell and a 0.038" plug gage will not pass through any of the triangular openings. The proper procedure is outlined on Illustration No 6. Reinstall the intake flame arrestor and make sure all fasteners and locking devices are in place and tight.
[12 MONTH]
9. [] **Item No 5** is the elbow (with optional adaptor flange). It is securely attached to the inlet flange of the intake flame arrestor and all fasteners and locking devices are in place and tight. No gasket is installed between the components and no check is required on **Joint "2-B"** as this is not considered a flameproof joint.
[WEEKLY]
10. [] **Item No 7** is the intake air shut-off valve. It is securely held between adapter flange of the elbow **Item No 5** (or a separate optional adapter flange), and the adapter flange of the filter housing **Item No 8** (or a second separate optional adapter flange). The intake air shut-off valve is securely held together between the two adapter flanges and all fasteners and locking devices are in place and tight. No gasket is installed between the components and no check is required on **Joint "3-A" and Joint "3-B"** as these are not considered flameproof joints.
[WEEKLY]
11. [] **Item No 6** is the optional flameproof port for monitoring the intake restriction. It is tightly installed into the intake pipe/manifold. A hose is connected to the flameproof port and the center plug is securely held in place with a retaining ring. If not installed, a pipe plug must be installed in its place.
[WEEKLY]
12. [] If an air compressor is installed, the air supply connection to the compressor must be located out-by (upstream) of the air intake flame arrestor and in-by (downstream) of the intake air cleaner, unless the compressor is fitted with its own air intake cleaner.
[WEEKLY]

DO NOT CHANGE WITHOUT MSHA APPROVAL

REVISION DATE: 08-04

DRY SYSTEMS TECHNOLOGIES®

8102 Lemont Road, Suite 700, Woodridge, Illinois 60517, USA

Phone: 630-427-2051 * Fax: 630-427-1036 * E-mail: eng@drysistemstech.com

M150-015-01 * PERMISSIBILITY CHECKLIST * Page 4

DST DRY SYSTEM® DIESEL POWER PACKAGE FOR 116 HP ISUZU 6BG1-MAP DIESEL ENGINE

13. [] *[WEEKLY]* **Item No 8** is the intake air cleaner housing. It may be connected to the air shut off valve No 7 with either rubber hoses, elbows and piping or directly with an adapter flange. The hoses must be securely attached with hose clamps and must have no damage or leakage.

DST Exhaust System

The **Exhaust System of the Model M150 DST Dry System® of this Diesel Power Package** includes a water-cooled exhaust manifold with integrated elbow, a water cooled bellows, a water-cooled pre-cooler with integrated elbow, a water-cooled catalyst, a water-cooled elbow, a heat exchanger with a water-cooled inlet-outlet box, an exhaust outlet elbow, an exhaust flame arrester, and a DPM filter housing with a disposable filter element.

Illustrations No 2, No 3 and No 4 depict the components of the exhaust system.

14. [] *[WEEKLY]* All components appear to be the same as shown on Illustrations **No 2, No 3 and No 4** in this Permissibility Checklist. There is no visible damage, cracks or dents on the exhaust system.
15. [] *[WEEKLY]* **Illustration No 2** depicts the first section of the DST exhaust system components located between the exhaust ports of the Isuzu diesel engine and the bellows outlet. All components appear as depicted and there is no visible damage, cracks or dents on the components.

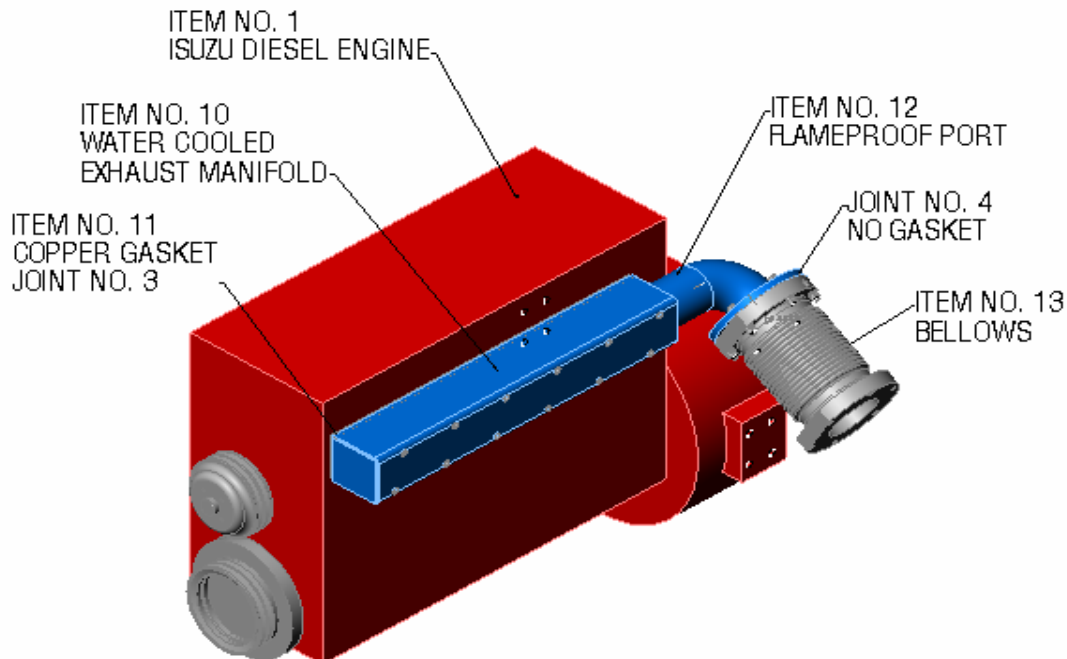

Illustration No 2: DST Exhaust System (First Section).

DO NOT CHANGE WITHOUT MSHA APPROVAL

REVISION DATE: 08-04

DRY SYSTEMS TECHNOLOGIES®

8102 Lemont Road, Suite 700, Woodridge, Illinois 60517, USA

Phone: 630-427-2051 * Fax: 630-427-1036 * E-mail: eng@drysystemstech.com

M150-015-01 * PERMISSIBILITY CHECKLIST * Page 5

DST DRY SYSTEM® DIESEL POWER PACKAGE FOR 116 HP ISUZU 6BG1-MAP DIESEL ENGINE

16. [] **Item No 10** is a water cooled exhaust manifold with an intergrated elbow. It is securely attached to the exhaust outlet ports of Item No 1, the Isuzu diesel engine and **Item No 11**, a copper gasket is installed between the components. All fasteners and locking devices are in place and tight. (Joint "3")
[WEEKLY]
17. [] A 0.0015" feeler gage cannot be inserted greater than 1/8" into **Joint "3"**.
[WEEKLY]
18. [] **Item No 12** is an optional flameproof port for monitoring the exhaust backpressure and for sampling of the untreated (engine-out) carbon monoxide. It is tightly installed into the pipe thread of the elbow section. A hose is connected to the flameproof port and a center plug is securely held with a retaining ring. If not used, an alternate pipe plug must be installed in its place.
[WEEKLY]
19. [] **Item No 13** is a water-cooled bellows assembly. It is securely attached to the outlet of the water-cooled exhaust manifold and all fasteners and locking devices are in place and tight. There is no gasket used at this Joint "4".
[WEEKLY]
20. [] A 0.004" feeler gage cannot be inserted into **Joint "4"**
[WEEKLY]
21. [] **Illustration No 3** depicts the second section of the DST exhaust system components located between and the bellows outlet and the heat exchanger. All components appear as depicted and there is no visible damage, cracks or dents on the components.
[WEEKLY]
22. [] **Item No 14** is a pre-cooler assembly with an integrated elbow. It is securely attached to the outlet flange of the bellows and all fasteners and locking devices are in place and tight. There is no gasket used at this joint 5.
[WEEKLY]
23. [] A 0.004" feeler gage cannot be inserted into **Joint "5"**
[WEEKLY]
24. [] **Item No 16-A** is an **optional** water-injection nozzle installed in the elbow section of the pre-cooler. The injector must be tightly installed in the elbow section of the pre-cooler. If not used, a pipe plug must be installed in its place. Either alternative is permissible.
[WEEKLY]
25. [] **Item No 15** is the water-cooled catalyst assembly. It is securely attached to the outlet of the pre-cooler and all fasteners and locking devices are in place and tight. There is no gasket used at this Joint "6"
[WEEKLY]
26. [] A 0.004" feeler gage cannot be inserted into **Joint "6"**
[WEEKLY]

DO NOT CHANGE WITHOUT MSHA APPROVAL

REVISION DATE: 08-04

DRY SYSTEMS TECHNOLOGIES®

8102 Lemont Road, Suite 700, Woodridge, Illinois 60517, USA

Phone: 630-427-2051 * Fax: 630-427-1036 * E-mail: eng@drysystemstech.com

M150-015-01 * PERMISSIBILITY CHECKLIST * Page 6

DST DRY SYSTEM® DIESEL POWER PACKAGE FOR 116 HP ISUZU 6BG1-MAP DIESEL ENGINE

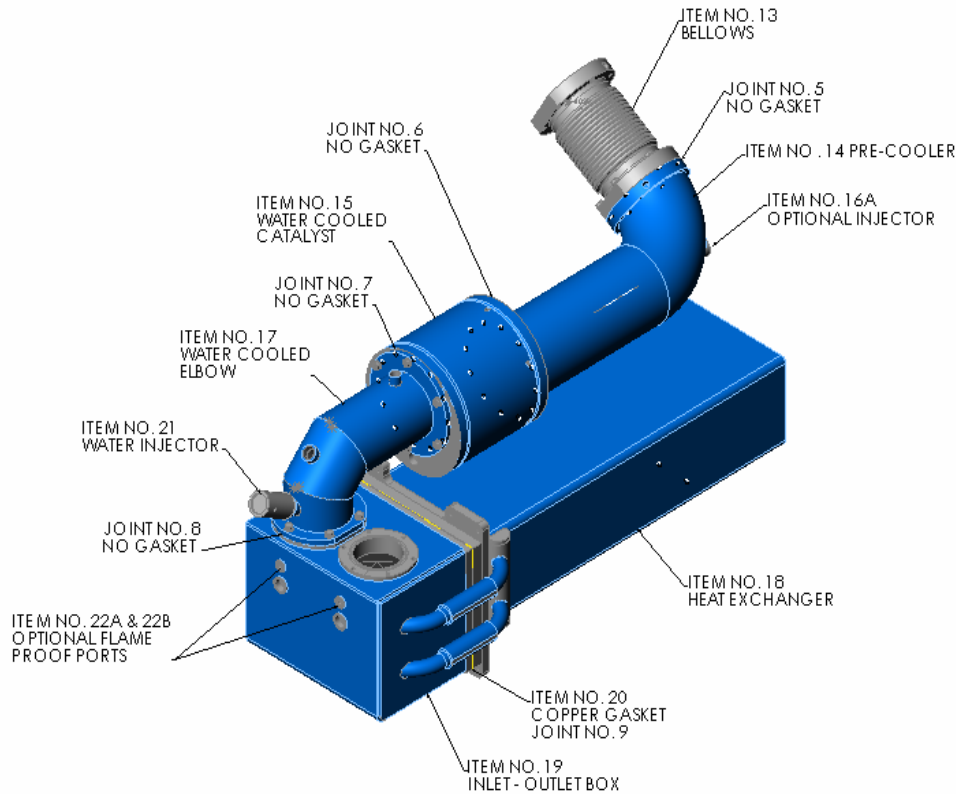

Illustration No 3: DST Exhaust System (Second Section).

27. [] *[WEEKLY]* **Item No 17** is the water-cooled elbow. Its inlet flange is securely attached to the outlet of the water-cooled catalyst and all fasteners and locking devices are in place and tight. There are no gaskets used at this **Joint "7"**.
The outlet flange of the water-cooled elbow is securely attached to the inlet flange of the inlet outlet box and all fasteners and locking devices are in place and tight. There are no gaskets used at this **Joint "8"**.
28. [] *[WEEKLY]* A 0.004" feeler gauge cannot be inserted into the **Joint "7" and Joint "8"**
29. [] *[WEEKLY]* **Item No 18** is the shell weldment of the heat exchanger and the tube bundle weldment. Only the flange is visible. The shell is attached to the tube bundle flange and no gasket is installed between the two flanges at **Joint "9-B"**. Attached to the other side of the tube bundle flange is **Item No 19**, the inlet-outlet box of the heat exchanger. A copper gasket, **Item No 20** is installed on **Joint "9"** between the inlet-outlet box and the tube bundle flange. The three flanges are securely attached to each other and all fasteners and locking devices are in place and tight.

DO NOT CHANGE WITHOUT MSHA APPROVAL

REVISION DATE: 08-04

DRY SYSTEMS TECHNOLOGIES®

8102 Lemont Road, Suite 700, Woodridge, Illinois 60517, USA

Phone: 630-427-2051 * Fax: 630-427-1036 * E-mail: eng@drysystemstech.com

M150-015-01 * PERMISSIBILITY CHECKLIST * Page 7

DST DRY SYSTEM® DIESEL POWER PACKAGE FOR 116 HP ISUZU 6BG1-MAP DIESEL ENGINE

30. [] A 0.0015" feeler gage cannot be inserted greater than 1/8" into the Joint "9".
[WEEKLY] The Joint "9-B" is not a flame-proof joint and does not need to be inspected.
31. [] **Item No 21** is the water-injection nozzle assembly. It is installed at the outside of the water-cooled elbow. The injector must be tightly installed into the elbow. If not used, a pipe plug must be installed in its place.
[WEEKLY]
32. [] **Items No 22-A and 22-B** are two OPTIONAL flame-proof ports to monitor the pressure differential across the heat exchanger. They are tightly installed at the end of the end of the inlet-outlet box. If no ports are installed, pipe plugs must be installed in their place. Either alternative is permissible.
[WEEKLY]
33. [] **Illustration No 4** depicts the third section of the DST exhaust system components that are located between the heat exchanger outlet and the filter housing. All components appear as depicted and there is no visible damage, cracks or dents on the components.
[WEEKLY]

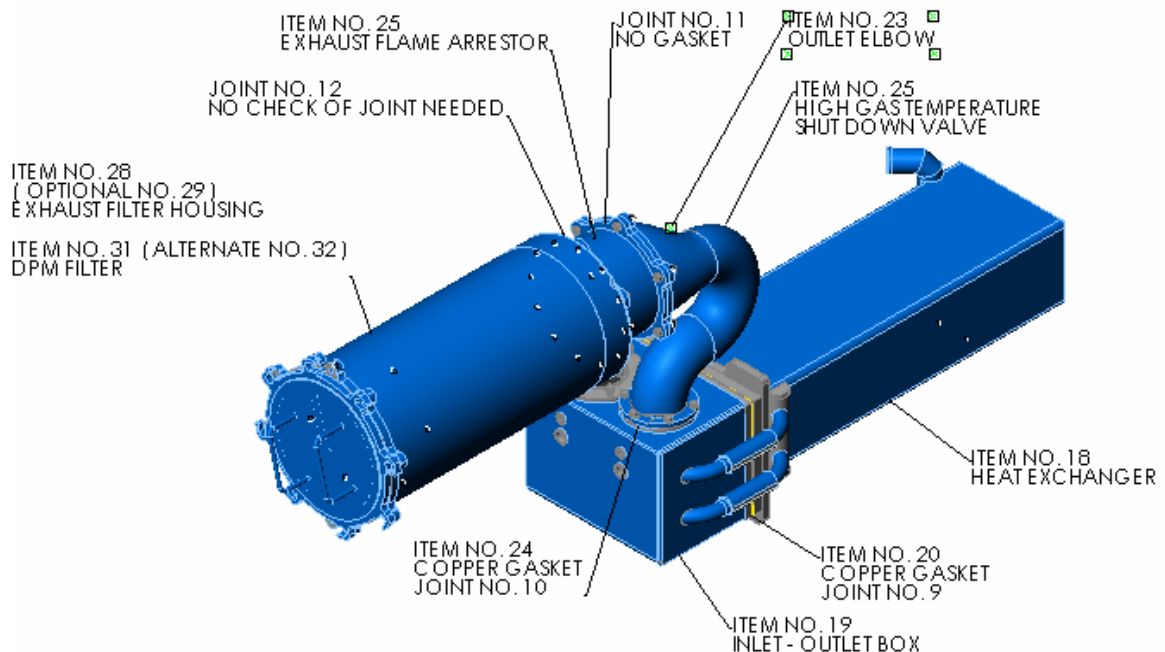

Illustration No 4: DST Exhaust System (Third Section)

DO NOT CHANGE WITHOUT MSHA APPROVAL

REVISION DATE: 08-04

DRY SYSTEMS TECHNOLOGIES®

8102 Lemont Road, Suite 700, Woodridge, Illinois 60517, USA
Phone: 630-427-2051 * Fax: 630-427-1036 * E-mail: eng@drysystemstech.com

M150-015-01 * PERMISSIBILITY CHECKLIST * Page 8

DST DRY SYSTEM® DIESEL POWER PACKAGE FOR 116 HP ISUZU 6BG1-MAP DIESEL ENGINE

34. [] **Item No 23** is the outlet elbow. It is securely attached to outlet flange of the inlet-outlet box and all fasteners are in place and tight. A copper gasket, **Item No 24**, is installed in Joint 10 between the two components
[WEEKLY]
35. [] A 0.0015" feeler gage cannot be inserted greater than 1/8" into the **Joint "10"**.
[WEEKLY]
36. [] **Item No 25** is the high exhaust gas temperature shut-down valve. It is tightly installed into the pipe threaded connection on top of the outlet elbow.
[WEEKLY]
37. [] **Item No 27** (not shown) is the high exhaust gas temperature probe for the gauge in the operator's cab. It is tightly installed into the pipe thread at the elbow section of the exhaust outlet elbow. If a probe is not installed, a pipe plug must be installed securely into the port.
[WEEKLY]
38. [] **Item No 26** is the exhaust flame arrester. It is securely attached to the outlet flange of the exhaust outlet elbow and all fasteners and locking devices are in place and tight. No gasket is installed on **Joint "11"** between the components.
[WEEKLY]
39. [] A 0.004" feeler gage cannot be inserted into the **Joint "11"**.
[WEEKLY]
40. [] Once every twelve-month, remove the exhaust flame arrester. The flame arrester core consists of a 4" wide stainless steel crimped ribbon element. There is no apparent damage and a 0.038" plug gage will not pass through any of the triangular openings. The procedure is outlined on Illustration 6. Reinstall the exhaust flame arrester, and make sure all fasteners and locking devices are in place and tight.
[12 MONTH]
41. [] **Item No 28** is the 10" exhaust particulate filter housing. **Item No 29**, the 16" exhaust particulate filter housing may be used as **alternative**. The housing is securely attached to the outlet of the exhaust flame arrester and all fasteners and locking devices are in place and tight. There is no gasket used on Joint "12" between the components. The Joint "12" is not a flameproof joint and needs not to be inspected.
[WEEKLY]
42. [] **Item No 31** is a 10" DPM filter element **must be marked "DST M40" or "PAAS M40"** on its end. If the alternate 16" filter housing is installed, a 16" alternate DPM filter element, Item No 32 must be used and it **must be marked "DST M30", DST M30-M or "PAAS M30"** on its end.
[WEEKLY]
43. [] Remove the exhaust particulate filter element from the exhaust particulate filter housing. Avoid direct contact with diesel soot. Visually inspect the outlet side of the flame arrester from the filter housing. There is no apparent damage to the crimped ribbon core of the exhaust flame arrester. Visually inspect the exhaust particulate filter element for damage or leaks.
[WEEKLY]

DO NOT CHANGE WITHOUT MSHA APPROVAL

REVISION DATE: 08-04

DRY SYSTEMS TECHNOLOGIES®

8102 Lemont Road, Suite 700, Woodridge, Illinois 60517, USA
Phone: 630-427-2051 * Fax: 630-427-1036 * E-mail: eng@drysystemstech.com

M150-015-01 * PERMISSIBILITY CHECKLIST * Page 9

DST DRY SYSTEM® DIESEL POWER PACKAGE FOR 116 HP ISUZU 6BG1-MAP DIESEL ENGINE

Reinstall the DST exhaust particulate filter element into the exhaust filter housing, or replace with a new DST exhaust particulate filter element if necessary.

The exhaust elbow, flame arrestor and filter housing may be positioned to face to the fan end or the flywheel end of the engine and the filter housing may have end-loading or side-loading provisions. Either arrangement is permissible.

NOTE: THE USE OF AFTERMARKET FILTERS WILL VOID THE MSHA APPROVAL

DST Shut Down Devices

44. []
[WEEKLY]

Illustration 5 depicts the location of the two (2) DST safety shut-down valves:

Item No S1 is a high exhaust temperature shutdown valve located on the exhaust outlet elbow.

Item No S2 is a high coolant temperature shutdown valve located in the junction box of the coolant return. Both valves are tightly installed and connected to the safety shut-down system.

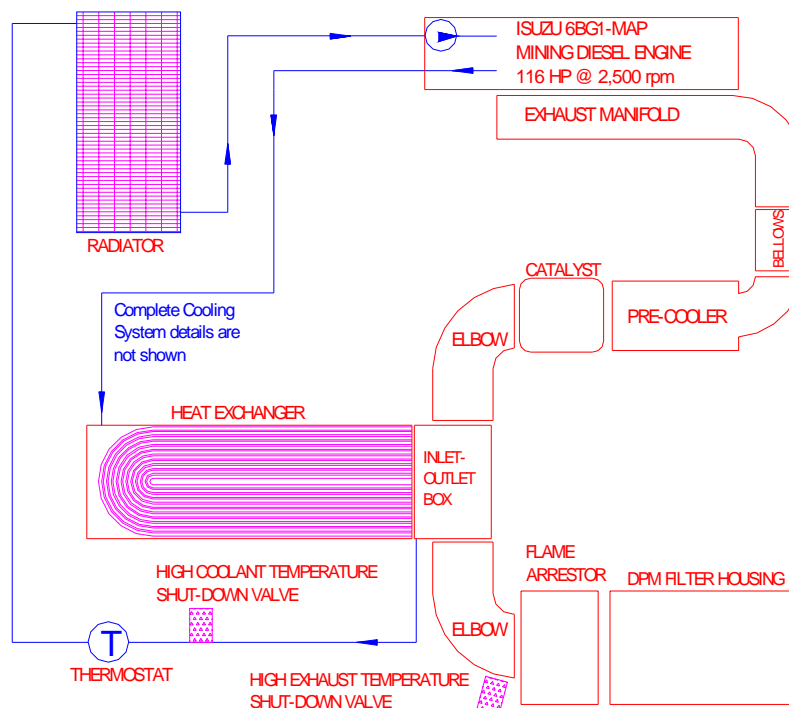

Illustration No 5 depicts the location of the Shut-down sensors

DO NOT CHANGE WITHOUT MSHA APPROVAL

REVISION DATE: 08-04

DRY SYSTEMS TECHNOLOGIES®

8102 Lemont Road, Suite 700, Woodridge, Illinois 60517, USA

Phone: 630-427-2051 * Fax: 630-427-1036 * E-mail: eng@drysystemstech.com

M150-015-01 * PERMISSIBILITY CHECKLIST * Page 10

DST DRY SYSTEM® DIESEL POWER PACKAGE FOR 116 HP ISUZU 6BG1-MAP DIESEL ENGINE

45. Both high temperature safety shutdown valves are to be removed and tested every 6 month as described below:
[EVERY 6 MONTH]
- a. [] Remove the high coolant temperature shutdown valve together with the well. Plug the opening in the junction box with a pipe plug while performing this test. Do not separate the valve from the well. Place the high coolant temperature shutdown valve into a 50-50 water & ethylene glycol mixture and slowly heat the mixture. The high coolant temperature shutdown valve must **open at 205° F and shut down the engine.**
- b. [] Remove the high exhaust gas temperature shutdown valve with an integral well. Do not separate the valve from the well. Close the port in the exhaust elbow with a pipe plug while performing this test. Place the high exhaust temperature shutdown valve and well into a non-flammable liquid, such as non-flammable transmission fluid or non-flammable hydraulic fluid, and slowly heat the fluid. The high exhaust gas temperature shutdown valve must **open between 275° F and 302° F and the engine must shut down before exceeding 302°F.**
- OPTIONAL:** This method of testing is intended to expose the high exhaust gas temperature shutdown valve to the uncooled hot exhaust gases of the system instead of hot fluid. Remove hoses from water cleaner injector. Remove injector from heat exchanger inlet/outlet box. Remove the high exhaust gas temperature shutdown valve with an integral well. Do not separate the valve from the well. Close the port in the exhaust elbow with a pipe plug while performing this test. Assemble a standpipe from pipe fittings. This standpipe should be threaded into the water injector location. Suspend the high exhaust gas temperature shutdown valve with the hose attached into this standpipe. A temperature measurement device such as a thermocouple or thermometer should also be placed in the standpipe. Operate the engine at moderate speed to subject the high exhaust gas temperature shutdown valve to the uncooled gases. Monitor the temperature. The high exhaust gas temperature shutdown valve must **open between 275° F and 302° F and the engine must shut down before exceeding 302° F.**
- c. [] Reinstall both temperature shutdown valves into their proper locations. Make sure that both valves are tightly installed and re-connected to the safety shut-down system.
46. [] With the engine running at intermediate speed, engage the engine stop valve, which is the normal method to shut-down the engine. **The engine must shut down IMMEDIATELY.**
[WEEKLY]
47. [] With the engine at idle speed of 850 RPM, activate the emergency shutdown switch. **The engine must shut down IMMEDIATELY.**
[WEEKLY]
48. [] Run the engine at high idle speed of 2,750 RPM. The total intake vacuum shown on the gauge in the operator's cab must not exceed 25 inches H₂O. The total exhaust backpressure shown on the gauge in the operators cab must not exceed 40 inches H₂O
[WEEKLY]

DO NOT CHANGE WITHOUT MSHA APPROVAL

REVISION DATE: 08-04

DRY SYSTEMS TECHNOLOGIES®

8102 Lemont Road, Suite 700, Woodridge, Illinois 60517, USA

Phone: 630-427-2051 * Fax: 630-427-1036 * E-mail: eng@drysystemstech.com

M150-015-01 * PERMISSIBILITY CHECKLIST * Page 11

DST DRY SYSTEM® DIESEL POWER PACKAGE FOR 116 HP ISUZU 6BG1-MAP DIESEL ENGINE

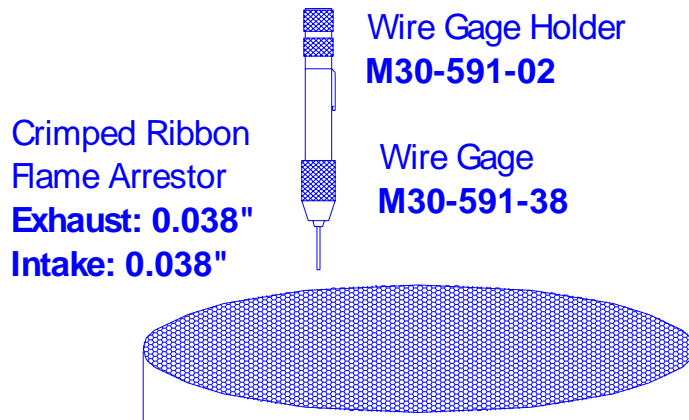

Illustration No 6: Flame Arrestor Checking Procedure

1. Remove the Flame Arrestor Assembly
2. Place the Flame Arrestor Assembly on a flat surface with a contrasting background under the flame arrestor, such as brattice cloth or clean white cloth.
3. Adequate lighting is required. Cap lamp lighting is not sufficient.
4. Visually inspect each side of the Flame Arrestor for openings or spaces obviously greater than the triangular openings of the core. These kinds of openings may have been caused by prying a screwdriver or another such object against or through the Flame Arrestor core during manufacturing or mine maintenance.
5. Visually inspect each side of the core for places where the windings of the flame arrestor core appear to be separated such that gaps can be seen. If such gaps exist, they must be checked as following:
 - a.) The only measuring tool considered acceptable for performing this evaluation is a 0.038 inch diameter calibrated plug gauge, sometimes called wire gauge. The Plug Gauge is to be mounted in
 - a) Gauge Holder weighing about 1.0 to 1.5 ounces and projecting at least 1.0 inch out of the end.
 - b.) Grasp the gauge holder lightly between the index finger and the thumb. Place the wire tip at the point in question, making sure the plug gauge is vertical. Using only the weight of the gauge and holder see if it will enter the apparent gap. Do not attempt to wiggle the gauge through the opening.
 - c.) If the plug gauge enters the opening, the flame arrestor core must not be used on permissible equipment.
 6. Visually inspect the triangles in the flame arrestor core (both sides) for triangles that appear to be larger than the rest. If such conditions exist, these openings must be checked as previously described in section 5 a, b and c.
 7. Finally, if the flame arrestor core passes all the above evaluations, a final check should be performed on at least 5 triangles on each side of the core with the procedure described in section 5 a, b and c. In performing this check, the tip of the plug gauge must be placed against a specific triangular opening. If this special care is not taken, the evaluation will be invalid.

This Permissibility Checklist contains 48 Items on 11 Pages with 6 Illustrations.

DO NOT CHANGE WITHOUT MSHA APPROVAL

REVISION DATE: August-2004