

DRY SYSTEMS TECHNOLOGIES®

DRY SYSTEM® DIESEL POWER PACKAGE PERMISSIBILITY CHECKLIST M268-001-01

Page 1 of 10

DST DRY SYSTEM®

MODEL M268

MSHA APPROVED DIESEL POWER PACKAGE

Based on MSHA 7F-005-0 Approved DST Model M50 Dry System®

RETROFITTED TO A
ATLAS COPCO WAGNER MODEL UT-45 LUBE TRUCK OR ST-2
AND A
100 HP CATERPILLAR 3304 PCNA DIESEL ENGINE

DRY SYSTEMS TECHNOLOGIES®

8102 Lemont Road, Suite 700
WOODRIDGE, IL 60517, USA
Phone: 630-427-2051 * Fax: 630-427-1036
E-mail: eng@drysystemstech.com

DO NOT CHANGE WITHOUT MSHA APPROVAL

REVISION 01 * DATED JUNE 2005

DRY SYSTEMS TECHNOLOGIES®

8102 Lemont Road, Suite 700, Woodridge, Illinois 60517, USA
Phone: 630-427-2051 * Fax: 630-427-1036 * E-mail: eng@drysystemstech.com

M268-001-01 * PERMISSIBILITY CHECKLIST * Page 2

DRY SYSTEM® DIESEL POWER PACKAGE FOR A 100 HP CATERPILLAR 3304 PCNA DIESEL ENGINE

Caterpillar 3304 PCNA Diesel Engine

1. [] It has been determined that the area, in which tests are to be performed, is in **FRESH AIR**.
2. [] The machine is equipped with a **Caterpillar 3304 PCNA**, four-cylinder naturally aspirated diesel engine.

Air Intake System

NOTE: This DST Model M268 Diesel Power Package may/or may not use the Air Intake System that was originally supplied by the original equipment manufacturer. Please refer to the applicable Permissibility Checklist when checking the Air Intake System.

DST Exhaust System

The **Exhaust System of the Model M268 DST Dry System® Diesel Power Package** was derived from the MSHA Part 7F-005-0 approved DST Model M50 and the MSHA Part 7F-021-0 approved DST Model M150 Diesel Power Packages. It includes an **Atlas Copco Wagner** water-cooled exhaust manifold with metallic gaskets and the following **Dry Systems Technologies® (DST)** supplied components: A water-cooled manifold outlet elbow, a water-cooled bellows assembly, a water-cooled catalyst, a water-cooled extension pipe, a heat exchanger with a water-cooled inlet/outlet box, an exhaust outlet pipe reducer, an exhaust flame arrestor, and an exhaust filter housing with a disposable paper element DPM filter.

Illustrations No. 1, No. 2 and No. 3 on the following pages depict the components of the exhaust system.

3. [] All components appear to be the same as shown on Illustration No. 1, No. 2 and No. 3 in this *[WEEKLY]* Permissibility Checklist. There is no visible damage, cracks, or dents on the exhaust system.
4. [] Illustration No. 1 depicts the first section of the Wagner and DST exhaust system components that are located between the exhaust ports of the Caterpillar diesel engine and the inlet of the manifold outlet elbow. All components appear as depicted and there is no visible damage, cracks or dents on the components.

DO NOT CHANGE WITHOUT MSHA APPROVAL

REVISION DATE: 06-05

DRY SYSTEMS TECHNOLOGIES®

8102 Lemont Road, Suite 700, Woodridge, Illinois 60517, USA
Phone: 630-427-2051 * Fax: 630-427-1036 * E-mail: eng@drysystemstech.com

M268-001-01 * PERMISSIBILITY CHECKLIST * Page 3

DRY SYSTEM® DIESEL POWER PACKAGE FOR 100 Hp CATERPILLAR 3304 PCNA DIESEL ENGINE

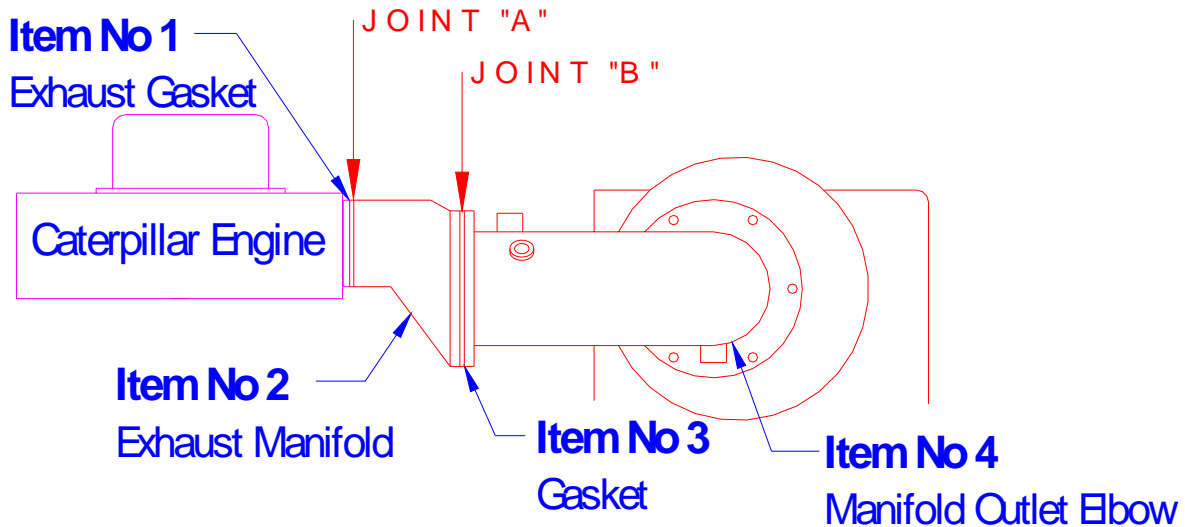

Illustration No 1: Exhaust System from Engine to Manifold Outlet Elbow

5. [] Item No. 2 is a water cooled exhaust manifold. It is securely attached to the exhaust ports of the Caterpillar diesel engine. Items No. 1 are two Caterpillar or Wagner supplied metallic exhaust gaskets installed between the components. All fasteners and locking devices are in place and tight. (Joint "A")
[WEEKLY]
6. [] A 0.0015" feeler gage cannot be inserted greater than 1/8" into the Joint "A".
[WEEKLY]
7. [] Item No. 4 is a water cooled manifold outlet elbow. It is securely attached to the outlet flange of the exhaust manifold. Item No. 3 is a Wagner supplied metallic gasket installed between the components. All fasteners and locking devices are in place and tight. (Joint "B")
[WEEKLY]
8. [] A 0.0015" feeler gage cannot be inserted greater than 1/8" into the Joint "B".
[WEEKLY]

DO NOT CHANGE WITHOUT MSHA APPROVAL

REVISION DATE: 06-05

DRY SYSTEMS TECHNOLOGIES®

8102 Lemont Road, Suite 700, Woodridge, Illinois 60517, USA
Phone: 630-427-2051 * Fax: 630-427-1036 * E-mail: eng@drysistemstech.com

M268-001-01 * PERMISSIBILITY CHECKLIST * Page 4

DRY SYSTEM® DIESEL POWER PACKAGE FOR 100 Hp CATERPILLAR 3304 PCNA DIESEL ENGINE

9. [] Illustration No. 2 depicts the second section of the DST exhaust components that are located between the manifold outlet elbow and the inlet of the inlet-outlet box. All components appear as depicted and there is no visible damage, cracks or dents on the components.
[WEEKLY]

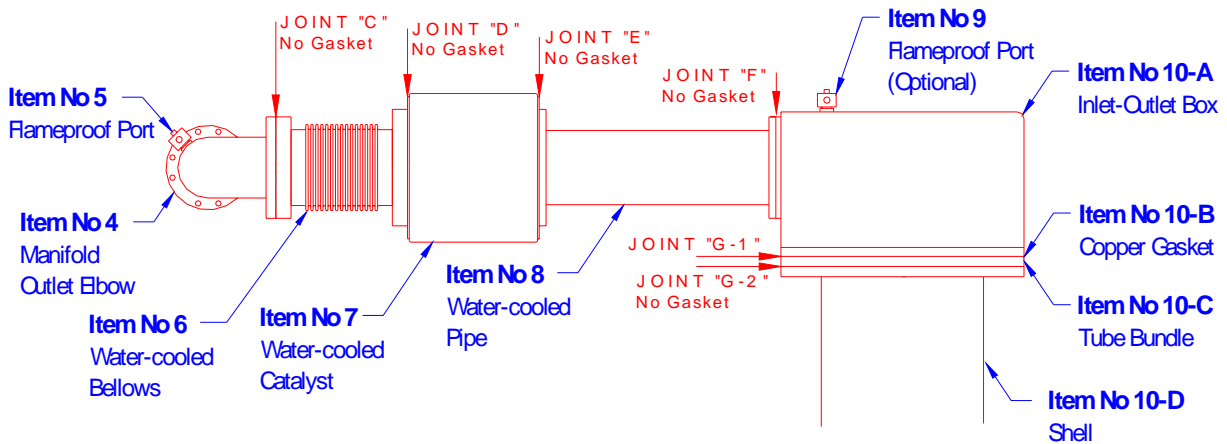

Illustration No. 2: Exhaust System from the Manifold Outlet Elbow to the Heat Exchanger

10. [] Item No. 5 is an optional flameproof port for monitoring the total backpressure and for sampling of the untreated (engine-out) carbon monoxide. It is tightly installed into the port on the manifold outlet elbow. A hose is connected to the flameproof port and the center plug is securely held in place with a retaining ring. If not installed, a pipe plug must be securely installed into the port.
[WEEKLY]
11. [] Item No. 6 is a water-cooled bellows assembly. It is securely attached to the outlet flange of the manifold outlet elbow and all fasteners and locking devices are in place and tight. No gasket is installed between the components (Joint "C"). The bellows convolutes are not visibly cracked or damaged and there is no indication of any coolant leaks.
[WEEKLY]

DO NOT CHANGE WITHOUT MSHA APPROVAL

REVISION DATE: 06-05

DRY SYSTEMS TECHNOLOGIES®

8102 Lemont Road, Suite 700, Woodridge, Illinois 60517, USA

Phone: 630-427-2051 * Fax: 630-427-1036 * E-mail: eng@drysystemstech.com

M268-001-01 * PERMISSIBILITY CHECKLIST * Page 5

DRY SYSTEM® DIESEL POWER PACKAGE FOR 100 Hp CATERPILLAR 3304 PCNA DIESEL ENGINE

12. [] A 0.004" feeler gage cannot be inserted into the Joint "C".
[WEEKLY]
13. [] Check the bellows for damage. If there is damage to the convolutes or visible leaks to the bellows are detected, replace the complete bellows assembly. After 24 months or 5,000 operating hours, remove and inspect the bellows assembly regardless of its apparent external condition. If there is damage to the inside convolutes or if there are leaks detected, replace the complete bellows assembly. When re-installing the original or a replacement bellows assembly, all fasteners and locking devices are in place and tight on both flanges. Check the flame gap on Joint "C" and Joint "D" as described under No. 11 and No. 14.
[SEE NOTE]
14. [] Item No. 7 is a water-cooled catalyst assembly. It is securely attached to the outlet flange of the bellows and all fasteners and locking devices are in place and tight. No gasket is installed between the components. (Joint "D")
[WEEKLY]
15. [] A 0.004" feeler gage cannot be inserted into the Joint "D".
[WEEKLY]
16. [] Item No. 8 is a water-cooled pipe. It is securely attached to the outlet of the catalyst assembly and all fasteners and locking devices are in place and tight. No gasket is installed between the components. (Joint "E")
[WEEKLY]
17. [] A 0.004" feeler gage cannot be inserted into the Joint "E".
[WEEKLY]
18. [] Item No. 10-A is the inlet-outlet box of the heat exchanger. Its inlet flange is securely attached to the outlet of the water-cooled pipe and all fasteners and locking devices are in place and tight. No gasket is installed between the components (Joint "F")
[WEEKLY]
19. [] A 0.004" feeler gage cannot be inserted into the Joint "F".
[WEEKLY]
20. [] Item No. 10-C is the tube bundle assembly of the heat exchanger. Only the flange is visible. The inlet/outlet box is securely attached to the inlet flange of the heat exchanger. Item No. 10-B is a copper gasket. It is installed between the flanges of the inlet-outlet box and the tube bundle flange. (Joint "G-1")
[WEEKLY]
Item No. 10-D is the shell assembly of the heat exchanger. It is securely attached to the tube bundle flange of the heat exchanger. No gasket is installed between the flanges. (Joint "G-2") The three flanges are securely tightened together and all fasteners and locking devices are in place and tight.
21. [] A 0.0015" feeler gage cannot be inserted greater than 1/8" into the Joint "G-1".
[WEEKLY]
Joint "G-2" is not a flameproof joint and requires no check.

DO NOT CHANGE WITHOUT MSHA APPROVAL

REVISION DATE: 06-05

DRY SYSTEMS TECHNOLOGIES®

8102 Lemont Road, Suite 700, Woodridge, Illinois 60517, USA
Phone: 630-427-2051 * Fax: 630-427-1036 * E-mail: eng@drysistemstech.com

M268-001-01 * PERMISSIBILITY CHECKLIST * Page 6

DRY SYSTEM® DIESEL POWER PACKAGE FOR 100 Hp CATERPILLAR 3304 PCNA DIESEL ENGINE

22. [] Items No. 9 are two OPTIONAL flameproof ports. The ports may be installed into the top of the inlet-outlet box to measure the pressure differential across the heat exchanger. These optional ports may be used in conjunction with an optional pressure differential gauge monitoring the heat exchanger. If installed, check that they are tightly installed into the ports of the inlet-outlet box. A hose is connected to each flameproof port and the center plug is securely held with a retaining ring. If not installed, pipe plugs must be securely installed into the ports.
[WEEKLY]
23. [] Illustration No. 3 depicts the third section of the exhaust system components that are located between the heat exchanger and the final exhaust pipe. All components appear as depicted and there is no visible damage, cracks or dents on the components.
[WEEKLY]

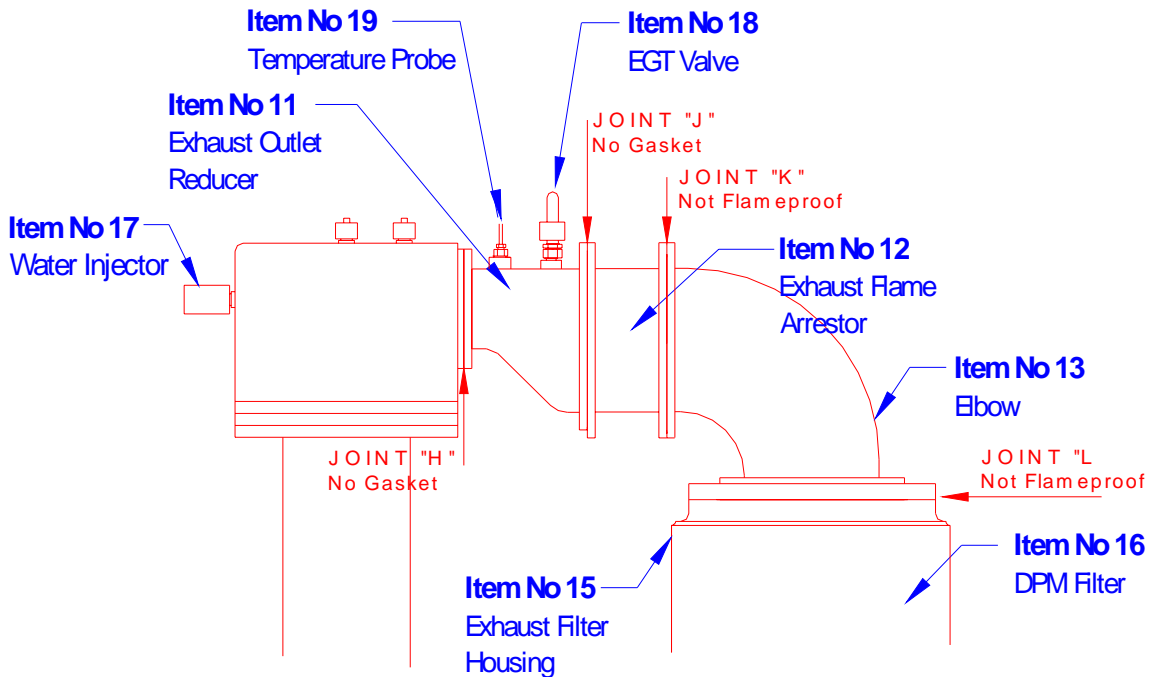

Illustration No. 3: Exhaust System between the Inlet-Outlet Box and the Final Outlet

24. [] Item No. 11 is the exhaust outlet reducer. It is securely attached to the outlet flange of the inlet-outlet box and all fasteners and locking devices are in place and tight. No gasket is installed between the components. (Joint "H")
[WEEKLY]
25. [] A 0.004" feeler gage cannot be inserted into the Joint "H".
[WEEKLY]

DO NOT CHANGE WITHOUT MSHA APPROVAL
REVISION DATE: 06-05

DRY SYSTEMS TECHNOLOGIES®

8102 Lemont Road, Suite 700, Woodridge, Illinois 60517, USA
Phone: 630-427-2051 * Fax: 630-427-1036 * E-mail: eng@drysistemstech.com

M268-001-01 * PERMISSIBILITY CHECKLIST * Page 7

DRY SYSTEM® DIESEL POWER PACKAGE FOR 100 Hp CATERPILLAR DIESEL ENGINE

26. [] Item No. 17 is a water injector. It is tightly installed into the pipe threaded port on the side of the heat exchanger inlet-outlet box.
[WEEKLY]
27. [] Item No. 18 is a high exhaust gas temperature shutdown valve. It is tightly installed into the *[WEEKLY]* the exhaust outlet reducer.
28. [] Item No. 19 is an optional high exhaust gas temperature probe for the gauge in the operator's cab. It is tightly installed into the exhaust outlet reducer. If a probe is not installed, a pipe plug must be installed securely into the port.
[WEEKLY]
29. [] Item No. 12 is an exhaust flame arrestor. It is securely attached to the outlet flange of the exhaust outlet reducer and all fasteners and locking devices are in place and tight. No gasket is installed between the components. (Joint "J")
[WEEKLY]
30. [] A 0.004" feeler gage cannot be inserted into the Joint "J".
[WEEKLY]
31. [] Once every twelve-months,remove the exhaust flame arrestor. The flame arrestor core consists of a 4" wide stainless steel crimped ribbon element. There is no apparent damage and a 0.038" plug gage will not pass through any of the triangular openings. The procedure is outlined on Illustration No. 5. Reinstall the exhaust flame arrestor, and make sure all fasteners and locking devices are in place and tight.
[12 MONTHS]
32. [] Item No. 13 is an elbow. It is securely attached to the exhaust flame arrestor and all fasteners and locking devices are in place and tight. No gasket is used between the two flanges and the Joint "K" is not considered flame proof. No further check is necessary on this joint.
[WEEKLY]
33. [] Item No. 15 is an exhaust particulate filter housing. It is securely attached to the elbow and all fasteners and locking devices are in place and tight. No gasket is used between the two flanges and the Joint "L" is not considered flame proof. No further check is necessary on this joint.
[WEEKLY]
34. [] Item No. 16 is a 16" particulate filter element and must be **must be marked "DST M30" or "PAAS M30"**.
[WEEKLY]
35. [] Remove the exhaust particulate filter element from the exhaust particulate filter housing. Avoid direct contact with diesel soot. Visually inspect the exhaust particulate filter element for damage or leaks. Reinstall the DST exhaust filter element into the exhaust filter housing, or replace with a new DST exhaust filter element if necessary.
[WEEKLY]

THE USE OF AFTERMARKET FILTERS WILL VOID THE MSHA APPROVAL.

DO NOT CHANGE WITHOUT MSHA APPROVAL

REVISION DATE: 06-05

DRY SYSTEMS TECHNOLOGIES®

8102 Lemont Road, Suite 700, Woodridge, Illinois 60517, USA
Phone: 630-427-2051 * Fax: 630-427-1036 * E-mail: eng@drysystemstech.com

M268-001-01 * PERMISSIBILITY CHECKLIST * Page 8

DRY SYSTEM® DIESEL POWER PACKAGE FOR 100 Hp CATERPILLAR DIESEL ENGINE

DST Shut Down Devices

36. [] As shown on Illustration No. 4, two safety shut-down valves are part of the DST Dry System.
[WEEKLY] Item No. S1 is the high exhaust temperature shutdown valve and is located on the exhaust outlet reducer.
Item No. S2 is the high coolant temperature shutdown valve and is located near the thermostat housing on the engine. Both valves are tightly installed and connected to the safety shut-down system.

37. Both high temperature safety shutdown valves are to be removed and tested every 6 months
[EVERY 6 MONTHS] as described below:

a. [] Remove the high coolant temperature shutdown valve and the integral well. Plug the opening in the engine with a pipe plug while performing this test. Do not separate the valve from the well. Place the high coolant temperature shutdown valve into a 50-50 water & ethylene glycol mixture and slowly heat the mixture. The high coolant temperature shutdown valve must **open at 205° F and shut down the engine.**

b. [] Remove the high exhaust gas temperature shutdown valve with an integral well. Do not separate the valve from the well. Close the port in the exhaust elbow with a pipe plug while performing this test. Place the high exhaust temperature shutdown valve and well into a non-flammable liquid, such as non-flammable transmission fluid or non-flammable hydraulic fluid, and slowly heat the fluid. The high exhaust gas temperature shutdown valve must **open between 275° F and 302° F and the engine must shut down before exceeding 302° F.**

OPTIONAL: This method of testing is intended to expose the high exhaust gas temperature shutdown valve to the uncooled hot exhaust gases of the system instead of hot fluid. Remove hose from water cleaner injector. Remove injector from heat exchanger inlet/outlet box. Remove the high exhaust gas temperature shutdown valve with the integral well. Do not separate the valve from the well. Close the port in the exhaust reducer with a pipe plug while performing this test. Install the high exhaust gas temperature shutdown valve with the hose attached into the threaded water injector location. Remove the flameproof port or pipe plug on the exhaust inlet side on the top of the inlet/outlet box. A temperature measurement device such as a thermocouple or thermometer should be placed in the inlet/outlet box where the port or pipe plug was located. Operate the engine at moderate speed to subject the high exhaust gas temperature shutdown valve to the uncooled gases. Monitor the temperature. The high exhaust gas temperature shutdown valve must **open between 275° F and 302° F and the engine must shut down before exceeding 302° F.**

c. [] Reinstall both temperature shutdown valves into their proper locations. Make sure that both valves are tightly installed and connected to the safety shut-down system.

DO NOT CHANGE WITHOUT MSHA APPROVAL

REVISION DATE: 06-05

DRY SYSTEMS TECHNOLOGIES®

8102 Lemont Road, Suite 700, Woodridge, Illinois 60517, USA
Phone: 630-427-2051 * Fax: 630-427-1036 * E-mail: eng@drysistemstech.com

M268-001-01 * PERMISSIBILITY CHECKLIST * Page 9

DRY SYSTEM® DIESEL POWER PACKAGE FOR 100 Hp CATERPILLAR DIESEL ENGINE

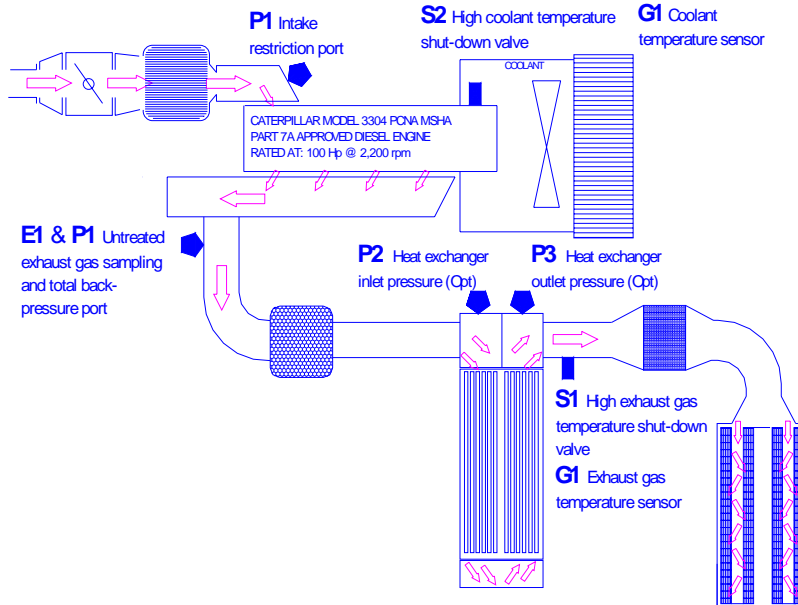

Illustration No. 4: Location of Pressure and Temperature Probes

System Operation

38. [] With the throttle pedal fully depressed, the transmission in neutral and all accessories dis-
[WEEKLY] engaged, the engine speed indicated on the gauge in the operator's cab does not exceed 2,350 RPM
39. [] Run engine at high idle speed of 2,250-2,350 RPM. The total intake restriction shown on the
[WEEKLY] gauge in the operator's cab must not exceed 25 inches H₂O.
The total exhaust restriction shown on the gauge in the operator's cab must not exceed 34 inches H₂O.

DO NOT CHANGE WITHOUT MSHA APPROVAL

REVISION DATE: 06-05

DRY SYSTEMS TECHNOLOGIES®

8102 Lemont Road, Suite 700, Woodridge, Illinois 60517, USA
Phone: 630-427-2051 * Fax: 630-427-1036 * E-mail: eng@drysystemstech.com

M268-001-01 * PERMISSIBILITY CHECKLIST * Page 10

DRY SYSTEM® DIESEL POWER PACKAGE FOR 100 Hp CATERPILLAR DIESEL ENGINE

Flame Arrestor Inspection Procedure

1. Remove the Flame Arrestor Assembly
2. Place the Flame Arrestor Assembly on a flat surface with a contrasting background under the flame arrestor, such as brattice cloth or clean white cloth. (Exhaust flame arrestor only)
3. Adequate lighting is required. Cap lamp lighting is not sufficient. (Exhaust flame arrestor only)
4. Visually inspect each side of the Flame Arrestor for openings or spaces obviously greater than the triangular openings of the core (Inlet side only on intake flame arrestor). These kinds of openings may have been caused by prying a screwdriver or another such object against or through the Flame Arrestor core during manufacturing or routine maintenance.
5. Visually inspect each side of the core for places where the windings of the flame arrestor core appear to be separated such that gaps can be seen. If such gaps exist, they must be checked as following:
 - a.) The only measuring tool considered acceptable for performing this evaluation is a 0.038 inch diameter calibrated plug gage, sometimes called wire gage. The Plug Gage is to be mounted in a Gage Holder must project at least 1.0 inch out of the end.
 - b.) Grasp the gage holder lightly between the index finger and the thumb. Place the wire tip at the point in question, making sure the plug gage is vertical. Using only the weight of the gage and holder, see if it will enter the apparent gap. Do not attempt to wiggle or push the gage through the opening.
 - c.) If the plug gage enters any opening, the flame arrestor core must not be used on permissible equipment.
6. Visually inspect the triangles in the flame arrestor core (both sides) for triangles that appear to be larger than the rest. If such conditions exist, these openings must be checked as previously described in section 5 a, b and c.
7. Finally, if the flame arrestor core passes all the above evaluations, a final check should be performed on at least 5 randomly selected triangles on each side (Inlet side only on intake flame arrestor) of the core with the procedure described in section 5 a, b and c. In performing this check, the tip of the plug gage must be placed against a specific triangular opening. If this special care is not taken, the evaluation will be invalid.

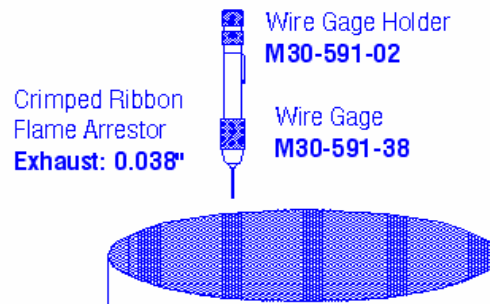

Illustration No 5: Flame Arrestor Checking Procedure

This Permissibility Checklist contains 39 Items on 10 Pages with 5 Illustrations.

DO NOT CHANGE WITHOUT MSHA APPROVAL

REVISION DATE: 06-05