

CONFIDENTIAL & PROPRIETARY

All data contained in this document is sole property of **DRY SYSTEMS TECHNOLOGIES** and is considered confidential and proprietary.

This document may not be reproduced, released to third parties, or used for purposes other than for which it was furnished, without express written consent of **DRY SYSTEMS TECHNOLOGIES**.

This document remains property of **DRY SYSTEMS TECHNOLOGIES** and must be returned upon request.

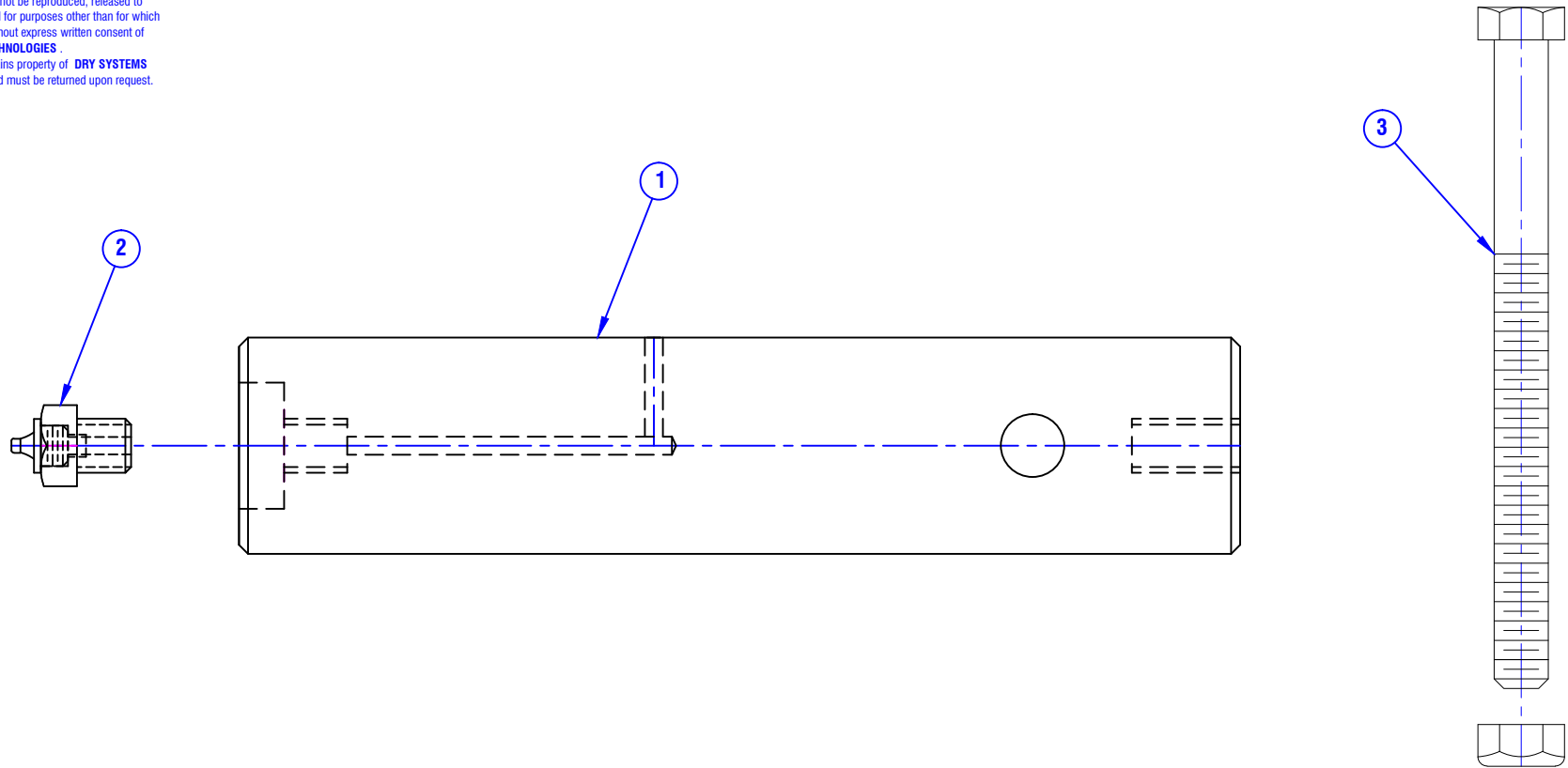

ITEM	PART NO.	QTY.	DESCRIPTION
1	M363-206-02	2	PIN, CYLINDER, ROD END
2	M350-686-02	2	GREASE BOLT
3	M515-500-26	2	PIN KEEPER BOLT - 3/4-10 X 6 GR 8 HHCS
	M515-560-04	2	3/4 - 10 TOP LOCK NUT

TOLERANCES

Linear unless noted
 Machined: ±0.005
 Fabricated: ±0.02
 Angular: ±1/2°
 Surface finish 125

REV	DATE	NAME	DESCRIPTION

DRY SYSTEMS TECHNOLOGIES

10420 RISING COURT
 WOODRIDGE, IL 60517
 Phone: 630-427-2051 Fax: 630-427-1036
 E-Mail: ansi@drysystemstech.com

DESCRIPTION		NO RECD
PIN, CYL ROD END ASSEMBLY		4
SCALE	DATE	DRAWN BY
Full	Dec 08 2015	W Fox
MATERIAL	APPROVED BY	
DRAWING NO	SECTION 1-13	

