

CONFIDENTIAL & PROPRIETARY  
 All data contained in this document is sole property  
 of DRY SYSTEMS TECHNOLOGIES and is considered  
 confidential and proprietary.  
 This document may not be reproduced, released to  
 third parties, or used for purposes other than for which  
 it was furnished, without express written consent of  
 DRY SYSTEMS TECHNOLOGIES.  
 This document remains property of DRY SYSTEMS  
 TECHNOLOGIES and must be returned upon request.

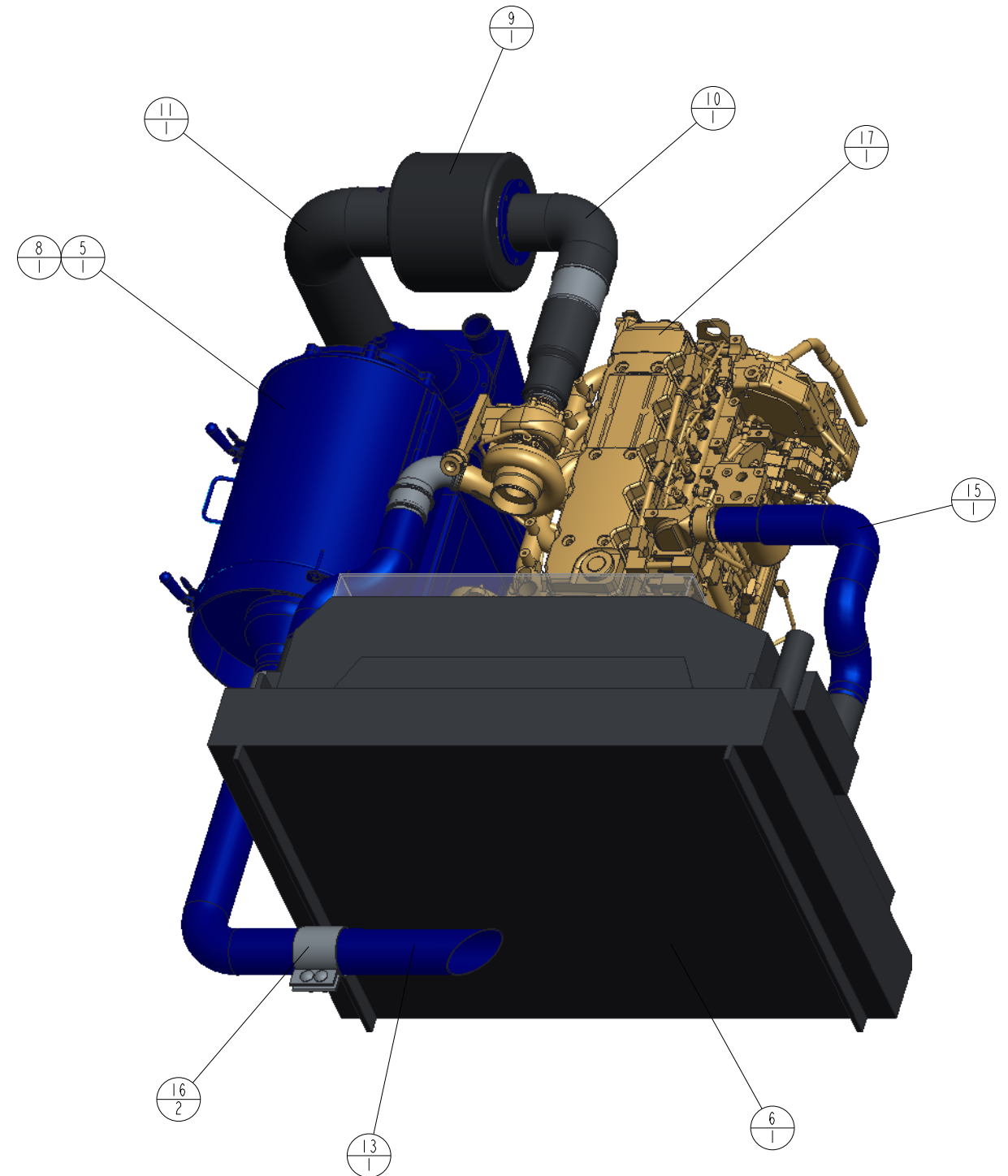
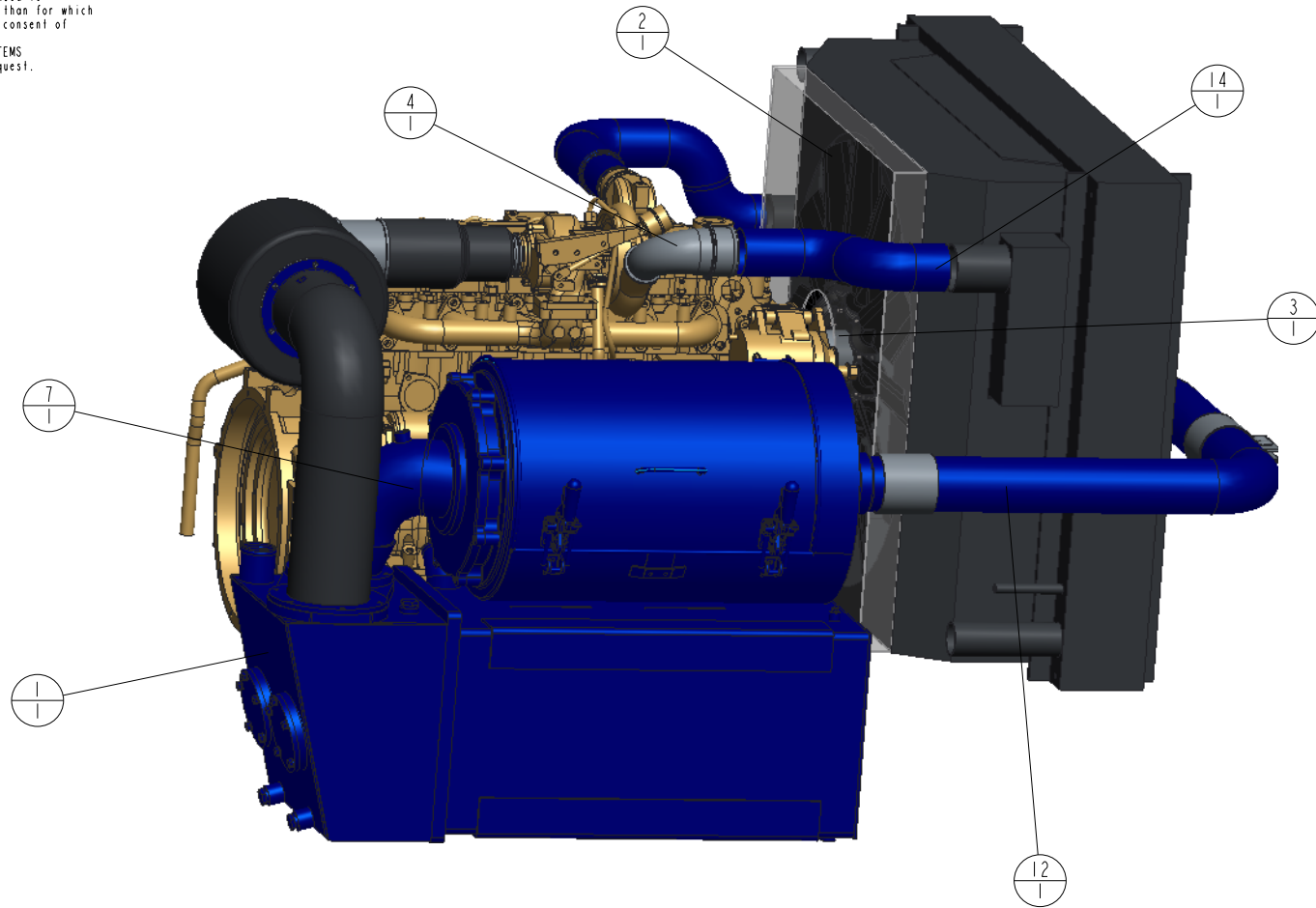

17	M500-236-02	Eng Spec, Cummins QSB6.7	1
16	M350-695-01	Clamp Strap, 4"	2
15	M350-263-67_4	Pipe, CAC Intake	1
14	M350-263-67_2	Pipe, CAC	1
13	M350-263-06	Tail Pipe, 4"	1
12	M347-263-05	Pipe, Exhaust Dillution	1
11	M347-240-01	Pipe, Catalyst to HE (Coated)	1
10	M347-205-01	Pipe, Turbo to Catalyst (Coated)	1
9	M347-200-02	Catalyst, 11" (Coated)	1
8	M30-411-01R	Filter, 16" DPM	1
7	M295-425-01	Elbow, exhaust (short)	1
6	M287-705-01C	Radiator Assembly Complete	1
5	M281-430-01	Housing, 16" filter	1
4	M267-501-239	Air Transfer Pipe	1
3	M250-733-01	Adapter, Fan Hub	1
2	M201-715-30	Fan, 32" Pusher	1
1	M190-301-01	Heat exchanger assembly	1
ITEM	PART NUMBER	DESCRIPTION	QTY

TOLERANCES  
 Linear unless noted  
 Machined:  $\pm 0.005$   
 Fabricated:  $\pm 0.01$   
 Angular:  $\pm 1/2^\circ$   
 Surface finish 125  
 Third angle projection

REV	DATE	NAME	DESCRIPTION

**DRY SYSTEMS TECHNOLOGIES**  
 10420 RISING COURT  
 WOODRIDGE, IL 60517  
 Phone: 630-427-2051  
 Fax: 630-427-1036  
 E-Mail: eng@drysystemstech.com

Description: **Tata Outby Pkg, Cummins QSB6.7**  
 Scale: **0.075** Date: **10/25/2019** Drawn By: **JDF**  
 Material: **See BOM** Approved By:  
 Drawing No. **M501072** Sheet **1/1**