

DRY SYSTEMS TECHNOLOGIES®

DRY SYSTEM® DIESEL ELECTRIC PACKAGE ELECTRICAL PERMISSIBILITY CHECKLIST M261-008-01

Page 1 of 6

MODEL M261 MSHA CERTIFIED DIESEL ELECTRIC PACKAGE

MSHA DE- 18-DEA070001-0
18-DEA100001-0

www.drysystemstech.com
E-mail: eng@drysystemstech.com

DO NOT CHANGE WITHOUT MSHA APPROVAL

REVISION 08 * DATED JANUARY 2018

DRY SYSTEMS TECHNOLOGIES®

www.drysystemstech.com E-mail: eng@drysystemstech.com

* ELECTRICAL PERMISSIBILITY CHECKLIST *

M261-008-01 Page 2

The component and function checks in this document that are identified as “weekly” must be performed during each weekly maintenance examination in accordance with 30 CFR, Section 75.1914. All checks must be performed in fresh air, in an area where permissible equipment is not required.

Machine Approval # _____ Serial # _____

Examination Date _____ Conducted By _____

1. [] All electrical enclosures have a MSHA plate attached that is clearly stamped with a MSHA certification number. The certification number must match the number listed in the table below.
[WEEKLY]

Enclosure	Quantity of Item Per Machine	Certification Number	Enclosure	Quantity of Item Per Machine	Certification Number
Alternator	1	07-JA040001-0	Camera	2 Optional	XP3938-0,-1
Headlight Switch	1	XP2456-2	Monitor	2 Optional	XP3844-1
Alt. Headlight Switch	1, Opt 2	XP3844-1	Strobelight	2 Optional	XP3938-0,-1
Alt. Headlight Switch	1	XP2166	Hourmeter	1 Optional	XP3938-0,-1
Alt. Headlight Switch	1	XP3846-0, -1			
Alt. Headlight Switch	1	XP1683-2			
Alt. Headlight Switch	1	18-XPA050010-0			
Headlight	4, Opt 5, Opt 6, Upto 11 if 12W	XP3938-0, -1			
Alt. Headlight	4, Opt 5, Opt 6	XP3221-0			
Alt. Headlight	4, Opt 5, Opt 6	XP1468-16, -31			
Connection Box	1 Optional	XP3844-1			
Strobelight	1 Optional, Opt 2	XP3843-2			

2. [] All electrical enclosures are securely mounted and all vulnerable electrical components are protected from physical damage.
[WEEKLY]
3. [] Lockwashers are provided for all bolts, screws, or studs that secure parts of the explosion-proof enclosures. All bolts, screws, and studs are in place and tightened.
[WEEKLY]
4. [] None of the fastenings used for joints on the explosion-proof enclosures are used for attaching non-essential parts or for making electrical connections.
[WEEKLY]
5. [] Use feeler gauges of the appropriate size to ensure that clearances in all accessible flame path joints, between the enclosures and the corresponding covers, are not exceeded. **(See Table Below)**
[WEEKLY]

DO NOT CHANGE WITHOUT MSHA APPROVAL
 REVISION 08 * DATED JANUARY 2018

DRY SYSTEMS TECHNOLOGIES®

www.drysystemstech.com E-mail: eng@drysystemstech.com

* ELECTRICAL PERMISSIBILITY CHECKLIST *

M261-008-01 Page 3

Component	Cert. No.	Clearance (Inches)
Alternator	07-JA040001-0	0.006 FIG 1
Headlight Switch	XP2456-2	0.006 FIG 1
Headlight Switch/Connection Box/Monitor	XP3844-1	0.002 FIG 2
Headlight Switch	XP1683-2, XP2166, XP3846-0,-1	0.003 FIG 2
Headlight Switch	18-XPA050010-0	0.004 FIG 2
Headlight	XP3221-0	0.002 FIG 2
Headlight	XP3938-0,-1, XP1468-16,-31	N/A
Strobelight	XP3843-2, XP3938-0,-1	N/A
Camera/Hourmeter/Dashlight	XP3938-0,-1	N/A

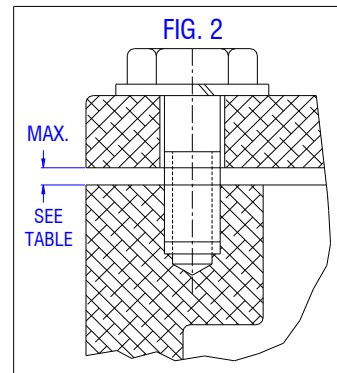
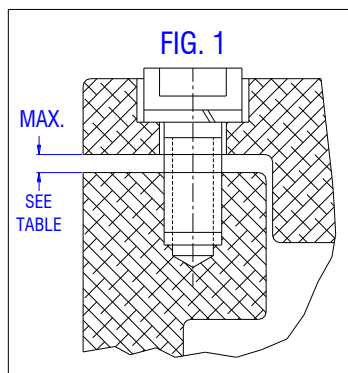

6. [] Headlight enclosures are intact, not cracked or broken, and the lenses are not loose.
[WEEKLY]

7. [] All lead entrances (packing glands) are tight and a 1/8" minimum clearance remains between the packing nut and stuffing box. (See Figure)
[WEEKLY]

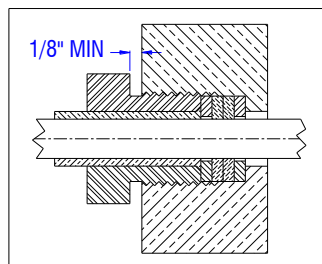

DO NOT CHANGE WITHOUT MSHA APPROVAL

REVISION 08 * DATED JANUARY 2018

DRY SYSTEMS TECHNOLOGIES®

www.drysystemstech.com E-mail: eng@drysystemstech.com

* ELECTRICAL PERMISSIBILITY CHECKLIST *

M261-008-01 Page 4

8. [] All packing nuts and stuffing boxes are secured from loosening by a locking screw, wire, or other means.
[WEEKLY]
9. [] All unused lead entrances are closed with metal plugs, which are secured in place by spot welding, brazing, or equivalent. **(See Figure)**
[WEEKLY]

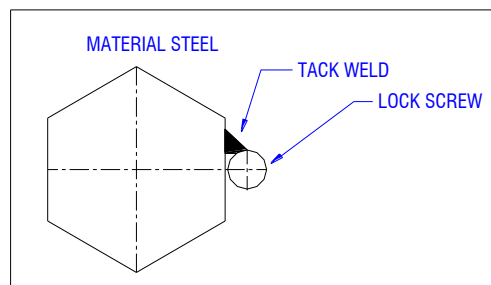

10. [] Headlights are installed at each end of the machine.
[WEEKLY]
11. [] Headlights are operable.
[WEEKLY]
12. [] Headlight switches do not control or operate any electrical circuits other than the headlights.
[WEEKLY]
13. [] Where required, electric cables outside of explosion proof enclosures are protected by flame resistant hose conduit. If hose conduit is used, it must be securely clamped at both ends and MSHA markings appear as Flame-Resistant", US MSHA.
[WEEKLY]
14. [] Cables are clamped in place to prevent undue movement.
[WEEKLY]
15. [] Cables are not subject to abrasion from sharp corners or edges.
[WEEKLY]
16. [] Cables are protected from mechanical damage by position, flame resistant hose conduit, metal tubing, or troughs. Note: Flexible or threaded rigid metal conduit is not acceptable.
[WEEKLY]

DO NOT CHANGE WITHOUT MSHA APPROVAL

REVISION 08 * DATED JANUARY 2018

DRY SYSTEMS TECHNOLOGIES®

www.drysystemstech.com E-mail: eng@drysystemstech.com

* ELECTRICAL PERMISSIBILITY CHECKLIST *

M261-008-01 Page 5

17. [] Cables are isolated from hydraulic lines, hydraulic components and fuel lines.
[WEEKLY]

The following checks should be performed whenever an explosion-proof electrical enclosure has been disassembled for service, repair, or inspection.

18. [] All joints forming the flame arresting paths (flanges or covers) are smooth and free from rust, corrosion and pitting.
19. [] Cables are flame resistant if not enclosed in hose conduit. This is indicated by "MSHA" markings on the cable.
20. [] Fuses are installed inside the alternator housing for overload protection of each power conductor in the electrical system. The fuses are of the proper dimensions for the fuse holders and do not exceed the current rating listed on drawings M261-003-01 or M261-007-01 or M261-012-01 or M261-014-01 or M261-029-01 or M261-031-01 or M261-035-01 or M261-038-01 or M261-041-01. (16GA Wire-7.5A, 14GA Wire-15A, 12GA Wire-20A)
21. [] All lead entrances (packing glands) are assembled so that the cable jacket penetrates into the enclosure.
22. [] Electrical connections inside the electrical enclosures are secure and are insulated where space is limited. The ground conductors are not broken and are securely attached.

Methane Monitor

If the machine has an optional methane monitor system installed, then the following checks apply.

23. [] The power supply enclosure has a MSHA plate attached that is clearly stamped with a MSHA certification number. The certification number is X/P 2133-13.
[WEEKLY]
24. [] All methane monitor components are securely mounted on the machine.
[WEEKLY]
25. [] All explosion-proof enclosures are assembled per checks 2, 3, and 4.
[WEEKLY]

DO NOT CHANGE WITHOUT MSHA APPROVAL

REVISION 08 * DATED JANUARY 2018

DRY SYSTEMS TECHNOLOGIES®

www.drysystemstech.com E-mail: eng@drysystemstech.com

* ELECTRICAL PERMISSIBILITY CHECKLIST *

M261-008-01 Page 6

- 26. [] Use a 0.004in feeler gauge to ensure that clearance between the power supply enclosure and the cover is not exceeded.
[WEEKLY]

- 27. [] All packing glands are installed correctly per checks 7, 8, and 9.
[WEEKLY]

- 28. [] The vent holes and the filter on the sensor head are not clogged.
[WEEKLY]

- 29. [] The methane monitor is properly calibrated to indicate zero (0) percent methane when no methane is present.
[WEEKLY]

- 30. [] Test the methane monitor by activating the test button. When the test button is depressed it simulates a signal from the detector sufficient to actuate all alarms and de-energize the shutdown relay.
[WEEKLY]

- 31. [] The methane monitor shall be maintained in permissible and proper operating condition and shall be calibrated at least once every 31 days.