

CONFIDENTIAL & PROPRIETARY
 All data contained in this document is sole property of DRY SYSTEMS TECHNOLOGIES and is considered confidential and proprietary. This document may not be reproduced, released to third parties, or used for purposes other than for which it was furnished, without express written consent of DRY SYSTEMS TECHNOLOGIES. This document remains property of DRY SYSTEMS TECHNOLOGIES and must be returned upon request.

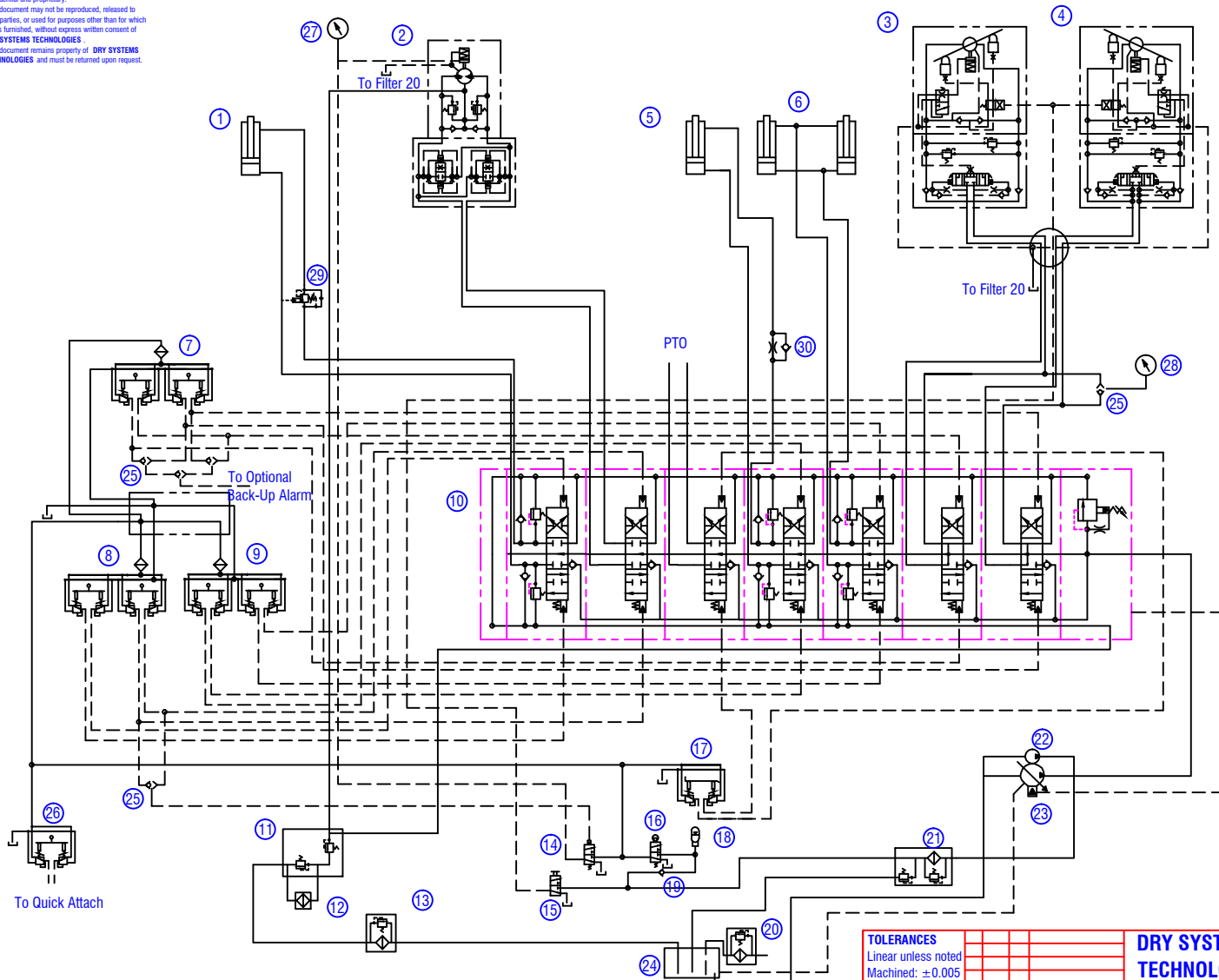

BILL OF MATERIAL

ITEM #	DESCRIPTION	PART NUMBER
1	Stick Cylinder	
2	Swing Motor	
3	Left Tram Motor	
4	Right Tram Motor	
5	Bucket Cylinder	
6	Boom Cylinders	
7	Pilots - Travel	
8	Pilots - Swing, Stick	
9	Pilots - Boom, Bucket	
10	Main Valve Bank	M383-504-01
11	Bypass Check	
12	Oil Cooler	
13	Filter	
14	Swing Release Valve	M350-888-01
15	Travel Speed Valve	M350-513-01
16	Safety Valve	M350-881-01
17	PTO Foot Valve	M383-508-01
18	Accumulator	
19	Check Valve	M350-580-01
20	Filter	
21	Pilot Filter, Relief Valve	
22	Pilot Pump	M383-502-01
23	Pump	M383-500-01
24	Hydraulic Tank	
25	Shuttle Valve	M350-655-01
26	Quick Attach Valve	M350-682-01
27	Gauge, Swing Brake	M350-890-01
28	Gauge, Tram Pressure	M507-623-01
29	Counterbalance Cartridge	M350-506-14
30	Flow Control Valve	M383-513-01

TOLERANCES
 Linear unless noted
 Machined: ±0.005
 Fabricated: ±0.02
 Angular: ±1/2°
 Surface finish 125

DRY SYSTEMS TECHNOLOGIES
 10420 RISING COURT
 WOODRIDGE, IL 60517
 Phone: 630-427-2051 Fax: 630-427-1038
 E-Mail: esp@drysystemstech.com

DESCRIPTION		Hydraulic Dia		NO. REVISIONS
SCALE	DATE	DRAWN BY	APPROVED BY	
	August 22, 2018	R Gibbs		
MATERIAL		DRAWING NO.		
		M383-003-02		