

M505-545-01 - BRAKE, DRIVE LINE

THE FAILSAFE BRAKE IS SPRING LOADED TO APPLY THE BRAKE AND HYDRAULIC PRESSURE IS REQUIRED TO RELEASE OR "HOLD OFF" THE BRAKE. NORMAL OPERATION IS TO HAVE THE BRAKE PRESSURIZED RUNNING. ANY FUNCTION WHICH REDUCES THE HYDRAULIC SYSTEM PRESSURE BELOW THE RELEASE PRESSURE OF THE BRAKE WILL CAUSE THE BRAKE TO BE APPLIED.

INSTALLATION INFORMATION:

1. REMOVE NUT AND WASHER FROM THE SHAFT.
2. INSTALL YOKES, WASHER AND NUT. TORQUE NUT TO 275-325 FT. LB.
3. MOVE BRAKE INTO POSITION AND ALIGN MOUNTING BOLT HOLES AND INSERT FOUR NONLUBRICATED 5/8 INCH BOLTS THROUGH HOLES IN EACH MOUNTING FOOT. TORQUE THE BOLTS TO 160 FT.-LB FOR GRADE 5, OR 230 FT.-LB FOR GRADE 8, ALTERNATELY UNTIL SNUG.
4. SLIDE YOKE OVER SHAFT.
5. CONNECT VEHICLE DRIVELINE TO BRAKE YOKES.
6. CONNECT HYDRAULIC SUPPLY LINE TO POWER PLATE INLET.
7. REMOVE FILL LEVEL PLUG FROM SIDE OF BRAKE. FILL BRAKE CAVITY WITH ESSO HYDRAULIC 56, EXXON HYDRAULIC 560, OR MOBIL 424 OIL UNTIL OIL RUNS OUT OF PORT. REPLACE PLUG AND TIGHTEN.

BRAKE DISASSEMBLY INFORMATION:

1. REMOVE BRAKE FROM MOUNTING POSITION AND REMOVE YOKES.
2. POSITION BRAKE WITH POWER PLATE UP, THE SIDE WITH MOUNTING FEET
3. REMOVE ASSEMBLY BOLTS ALTERNATELY KEEPING POWER PLATE PARALLEL TO THE HOUSING TO PREVENT DAMAGE TO BEARINGS. USE EXTREME CAUTION: SPRINGS CAN CAUSE POWER PLATE ASSEMBLY TO POP OFF HOUSING.
4. AFTER THE ASSEMBLY BOLTS HAVE BEEN REMOVED, REMOVE POWER PLATE SUB ASSEMBLY FROM BRAKE.
5. REMOVE SHAFT AND DISC STACK FROM THE BRAKE. IF THE STACK IS TO BE SERVICED USE A SHOP PRESS. REMOVE THE BEARING CONES FROM SHAFT.
6. REMOVE PRIMARY PLATE, SPRINGS AND SPRING RETAINER FROM HOUSING SPRING POCKET.
7. REMOVE PISTON FROM POWER PLATE BY INTRODUCING LOW-PRESSURE AIR, 15 PSI [1.0 BAR], INTO HYDRAULIC INLET. MAKE SURE THE PISTON IS DIRECTED AWAY FROM THE OPERATOR. REMOVE O-RINGS FROM THE O.D. AND I.D. OF THE GROOVE OF THE PISTON.)
NOTE: IF THE BEARING AND/OR SEALS ARE REMOVED, BOTH MUST BE REPLACED. SEAL CAN BE REMOVED BY PRYING IT OUT WITH AN APPROPRIATE TOOL. CARE MUST BE TAKEN NOT TO DAMAGE THE BORE.

ASSEMBLY INFORMATION:

IMPORTANT: THERE MAY BE MORE PARTS IN A SERVICE KIT THAN YOUR BRAKE REQUIRES. CHECK THE PARTS LIST CAREFULLY FOR THE EXACT QUANTITY. SPACE THE SPRINGS AS SHOWN ON THE SPRING ORIENTATION.

USE THE REVERSE OF THE DISASSEMBLY PROCEDURE WITH THE FOLLOWING NOTES AND ADDITIONS:

1. WORN AND DAMAGED O-RINGS OR WORN BACKUP RINGS MUST BE REPLACED PRIOR TO REASSEMBLY.
2. CYLINDER OF THE POWERPLATE, PISTON, AND O-RINGS MUST BE PRE-LUBED WITH SYSTEM HYDRAULIC FLUID PRIOR TO REASSEMBLY.
3. PISTON ASSEMBLY:
ASSEMBLE PISTON INTO POWER PLATE USING A SHOP PRESS. TAKE CARE NOT TO DAMAGE THE O-RING OR TEFLON BACKUP RINGS. VISUALLY ALIGN THE CENTER OF THE CUTOUTS IN THE PISTON WITH THE TORQUE PIN HOLES IN THE POWER PLATE.
CAUTION: THE DEPTH THE PISTON IS INSTALLED INTO THE POWER PLATE IS CRITICAL. THE SURFACE OF THE PISTON AT THE CUTOUTS MUST BE FLUSH TO 0.120 [3.0 mm] BELOW THE SURFACE OF THE POWER PLATE OR PISTON WILL COCK RESULTING IN A COMPLETE LOSS OF BRAKING.
4. BEARING ASSEMBLY:
USING A SHOP PRESS INSTALL ONE CONE ON THE SHAFT. BEARING MUST BE SEATED TIGHT AGAINST THE STOP. PRESS ONLY ON THE INNER RACE OF THE BEARING CONE, NOT ON THE ROLLERS. INSTALL THE STATIONARY AND ROTATING DISCS ON THE SHAFT. NOTE THE ORDER OF THE DISCS IN RELATIONSHIP TO THE ENDS OF THE SHAFT. PRESS THE OTHER CONE ONTO THE SHAFT OBSERVING THE PRECEDING CAUTIONS.
5. BRAKE ASSEMBLY:
INSTALL PARTS IN REVERSE ORDER OF DISASSEMBLY LEAVING THE SHAFT SEALS TO LAST. RELEASE THE BRAKE WITH 300 PSI [20.7 BAR] AND MEASURE THE TORQUE TO ROTATE THE SHAFT. THE FREE ROLLING TORQUE OF THE BRAKE SHAFT IS AN INDICATION OF BEARING SEATING AND FIT THE ROLLING TORQUE SHOULD BE 20 IN.-LB [2.26 Nm]. MAXIMUM.
IF TORQUE DOES NOT MEET SPECIFICATION, CHECK THAT THE BEARINGS ARE WELL SEATED
6. LIP SEAL ASSEMBLY:
AFTER THE BRAKE IS ASSEMBLED, INSTALL THE SHAFT SEALS WITH CAUTION NOT TO CUT THE SEAL LIPS ON THE SHAFT SPLINES. THE SEAL IS INSTALLED WITH TWIN LIPS FACING OUTWARDS, AWAY FROM THE BRAKE. THE SINGLE LIP WILL FACE INWARDS.

SERVICE KIT INFORMATION:

- BEARING KIT: M505-545-04 INCLUDES SEALS, RETAINING RINGS, AND BEARINGS.
- STACK KIT: M505-545-05 INCLUDES TORQUE PINS, PRIMARY, STATIONARY, ROTATING DISCS AND COMPRESSION SPRINGS
- O-RING KIT: M505-545-06 INCLUDES O-RINGS, BACKUP RINGS, AND INTERNAL GASKET.

REF: GENERAL ASSEMBLY VIEW 8007

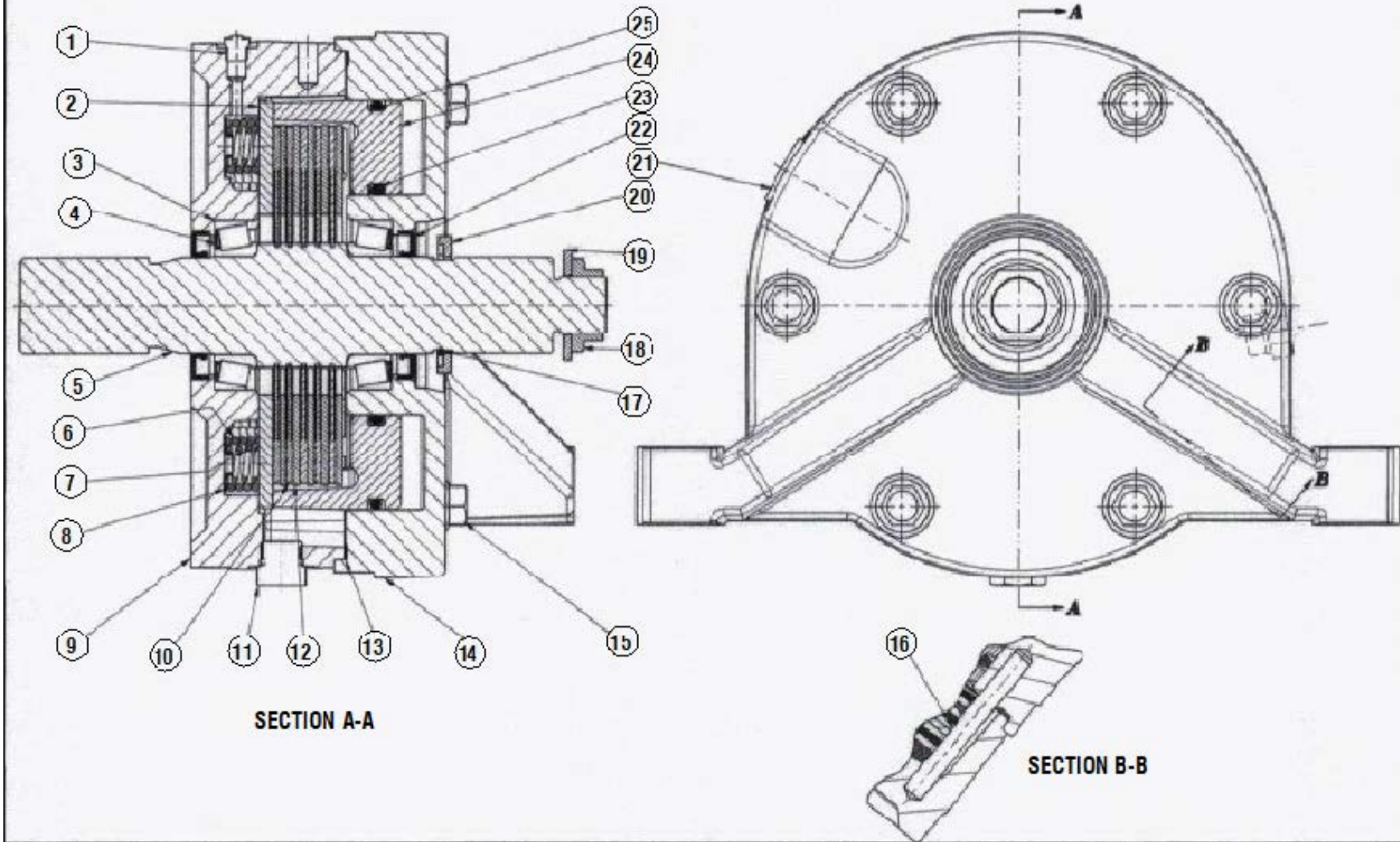
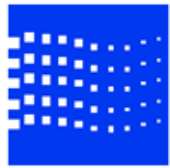

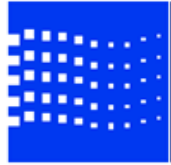

<u>Item</u>	<u>Qty</u>	<u>Part Number</u>	<u>Description</u>
1	1	M505-545-07	Pressure Release Valve
2	1	M505-545-08	Primary Disc
3	2	M505-545-09	Tapered Roller Bearing (Cup)
4	2	M505-545-10	Tapered Roller Bearing (Cone)
5	1	M505-545-11	Splined Shaft
6	18	M505-545-12	Compression Spring
7	18	M505-545-13	Compression Spring
8	1	M505-545-14	Spring Retainer
9	1	M505-545-15	Painted Housing
10	5	M505-545-16	Rotating Disc
11	2	M505-545-17	Hex Head Plug
12	5	M505-545-18	Stationary Disc
13	1	M505-545-19	Gasket
14	1	M505-545-20	Painted Power Plate
15	6	M505-545-21	Hex Bolt
16	2	M505-545-22	Torque Pin
17	1	M505-545-23	Retaining Ring
18	1	M505-545-02	Nut
19	1	M505-545-03	Washer
20	1	M505-545-24	Spacer
21	1	M505-545-25	Protective Plug
22	2	M505-545-26	Oil Seal
23	1	M505-545-27	O-Ring
24	1	M505-545-28	Piston
25	1	M505-545-29	O-Ring
26	1	M505-545-30	Caution Tag (Not Shown)

