

**CONFIDENTIAL & PROPRIETARY**

All data contained in this document is sole property of **DRY SYSTEMS TECHNOLOGIES** and is considered confidential and proprietary.

This document may not be reproduced, released to third parties, or used for purposes other than for which it was furnished, without express written consent of **DRY SYSTEMS TECHNOLOGIES**.

This document remains property of **DRY SYSTEMS TECHNOLOGIES** and must be returned upon request.

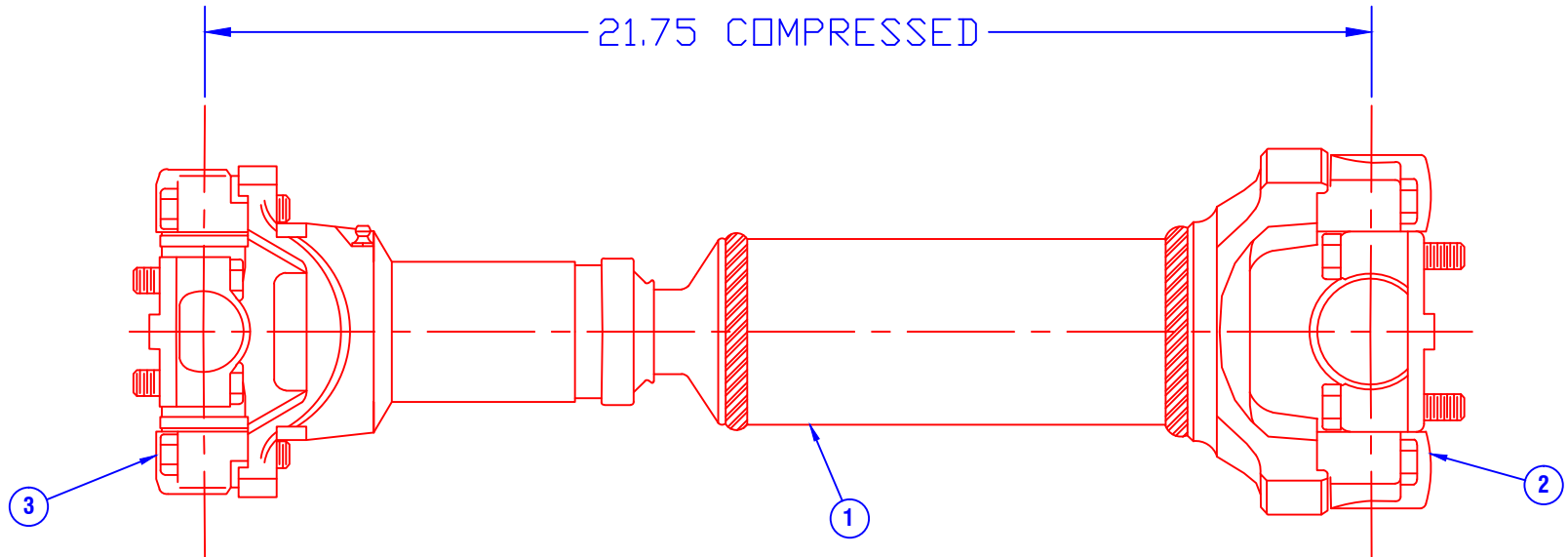

ITEM	PART NUMBER	QUAN.	DESCRIPTION
1	M350-521-01	1	DRIVE LINE Includes U-Joints
2	M506-627-01	1	UNIVERSAL JOINT
3	M506-626-01	1	UNIVERSAL JOINT

**SECTION 3-13**

<b>TOLERANCES</b> Linear unless noted Machined: ±0.005 Fabricated: ±0.02 Angular: ±1/2° Surface finish 125					<b>DRY SYSTEMS TECHNOLOGIES</b> 10420 RISING COURT WOODRIDGE, IL 60517 Phone: 630-427-2051 Fax: 630-427-1036 E-Mail: <a href="mailto:andi@drysystemstech.com">andi@drysystemstech.com</a>	DESCRIPTION DRIVE LINE - BEARING TO FRONT AXLE	NO RECD	
	SCALE	DATE	DRAWN BY					
	Full	APRIL 07 2015	Ward Fox					
	MATERIAL	APPROVED BY						
	DRAWING NO							
M350-521-01								