

CONFIDENTIAL & PROPRIETARY

All data contained in this document is sole property of **DRY SYSTEMS TECHNOLOGIES** and is considered confidential and proprietary.

This document may not be reproduced, released to third parties, or used for purposes other than for which it was furnished, without express written consent of **DRY SYSTEMS TECHNOLOGIES**.

This document remains property of **DRY SYSTEMS TECHNOLOGIES** and must be returned upon request.

To Safety System

To Water Injection System

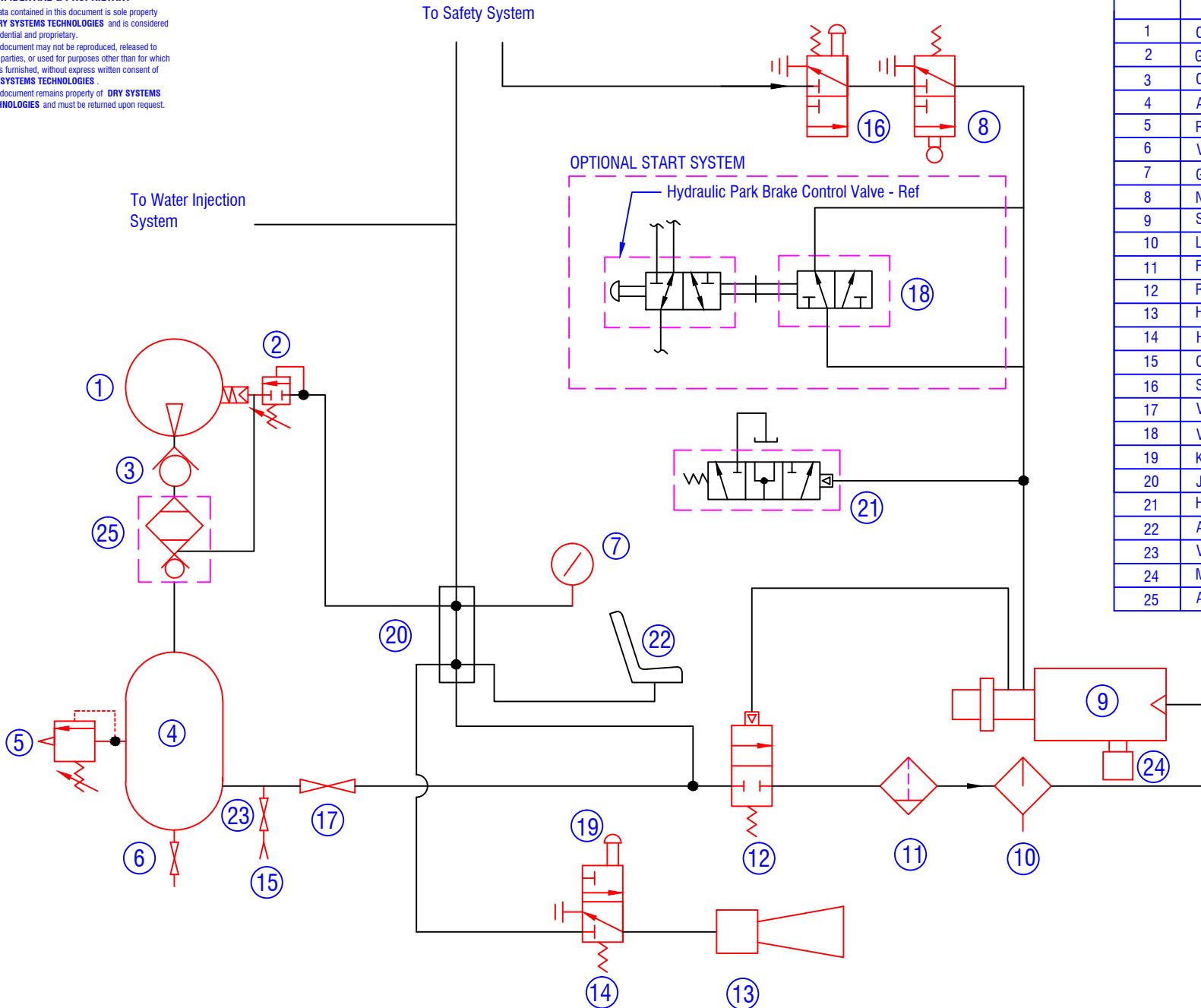

		PART NUMBER
1	Compressor	Supplied w/ Engine
2	Governor	M350-576-01
3	Check Valve	M350-577-01
4	Air Tank	M350-514-01
5	Relief Valve	M350-517-01
6	Valve, Ball, 1/2"	M350-573-01
7	Gauge, Panel Mt	M350-886-01
8	Neutral Start Valve	M350-572-01
9	Starter	M250-510-01
10	Lubricator	M250-512-01
11	Filter / Separator	M250-513-01
12	Relay Valve	M250-511-01
13	Horn	M350-571-01
14	Horn Valve	M350-589-01
15	Charge Point	M350-574-01
16	Start Valve	M30-558-01
17	Valve, Ball, 1", Locking	M350-575-02
18	Valve, Start (Opt)	M30-547-01
19	Knob, Horn	M350-590-01
20	J Block	M350-622-01
21	Hyd Div Valve	M350-566-01 REF
22	Air Ride Seat	M350-531-02 REF
23	Valve, Ball, 1/2"	M350-579-01
24	Muffler, Air Starter	M507-682-01
25	Air Dryer (Opt)	

TOLERANCES

Linear unless noted
 Machined: ±0.005
 Fabricated: ±0.02
 Angular: ±1/2°
 Surface finish 125

REV	DATE	NAME	DESCRIPTION
02	3/11/18	JDF	Removed ball valve between comp. & tank
01	7/6/15	wfox	Revised to show standard machine as-built

DRY SYSTEMS TECHNOLOGIES

8102 LEMONT ROAD, SUITE 700
 WOODRIDGE, IL 60517
 Phone: 630-427-2051 Fax: 630-427-1036
 E-Mail: eng@drysystemstech.com

DESCRIPTION		NO RECD	
Air Start Circuit-Cummins 8.3			
SCALE	DATE	DRAWN BY	APPROVED BY
NONE	DEC 2010	DHR	
DRAWING NO			
M350-005-02			

