

**Dry Systems
Technologies**

M261-512-01 Light Switch Box

Dual SW

SECTION 7-12

PA Approval No. 1185-92

XP Model No. 35400

XP Approval No. 3844-1

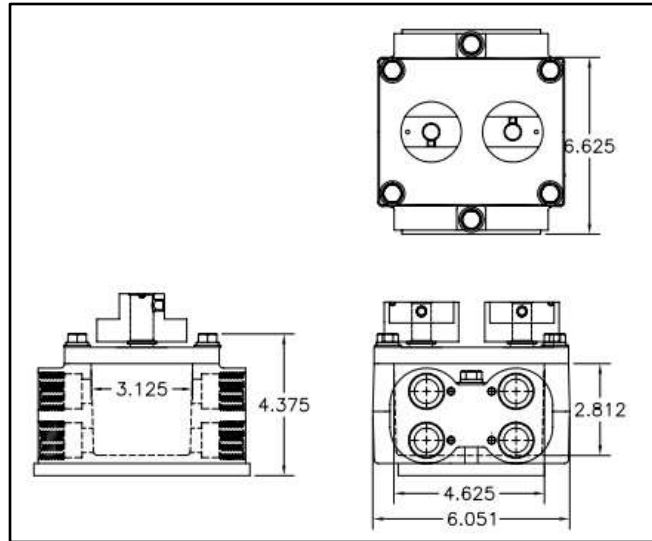
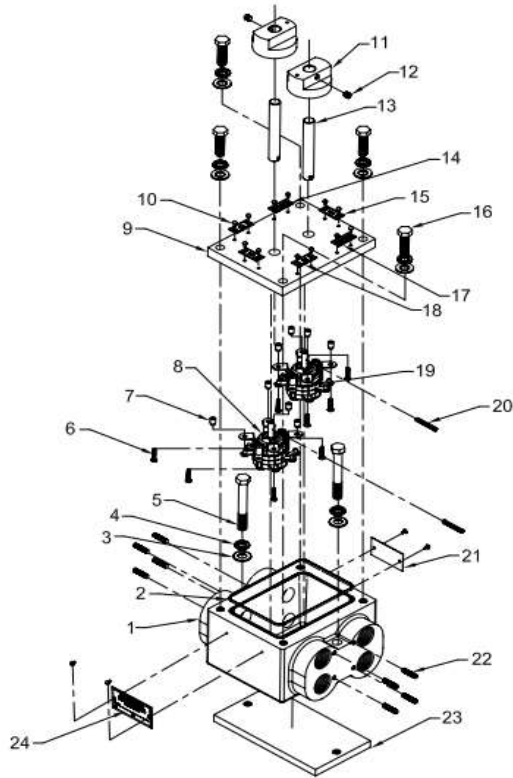

Item	Part Number	Qty	Description	
1	M261-512-07	1	Housing Machined Aluminum	
2	M261-512-06	1	O-Ring	
3	M250-107-05	6	3/8" Flat Washer	
4	M600-123-01	6	3/8" Lock Washer	
5	M600-187-01	2	3/8" - 16 x 3" Hex Head Bolt	
6	M261-501-12	8	#6 - 32 x 5/8" Pan Head Screw Stainless Steel	
7	M261-501-11	8	Standoff w/ Swage	
8	M261-501-02*	2	3 Position Switch	
9	M261-512-03	1	Cover Mach. For Two Switches 3pos.ele	
10	M261-502-10	16	Drive Screw #4 x 3/16"	
11	M261-512-02	2	Switch Knob Special for 2 Switch Box	
12	M261-501-07	12	Set Screw 1/4"-20 x 1/4"	
13	M261-501-02*	2	Shaft for Standard Switch Box	
14	M261-512-04	1	Front Tag	
15	M261-501-05	2	Off Tag	
16	M600-124-01	2	3/8"-16 x 1 1/4" Hex Head Bolt	
17	M261-512-05	1	Rear Tag	
18	M261-501-04	2	On Tag	
19	M261-501-08	2	Ground Lug	
20	M261-501-02*	2	1/8" x 3/4" Roll Pins	
21	M261-502-12	1	PA Tag	
22	M261-502-08	8	Stainless Set Screw 1/4"-20 x 1"	
23	M261-512-08	1	Plate	
24	M261-501-14	1	Certification Tag	

*Part of the Switch & Shaft Assembly
M261-501-02, not sold individually