

CONFIDENTIAL & PROPRIETARY

All data contained in this document is sole property of **DRY SYSTEMS TECHNOLOGIES** and is considered confidential and proprietary. This document may not be reproduced, released to third parties, or used for purposes other than for which it was furnished, without express written consent of **DRY SYSTEMS TECHNOLOGIES**. This document remains property of **DRY SYSTEMS TECHNOLOGIES** and must be returned upon request.

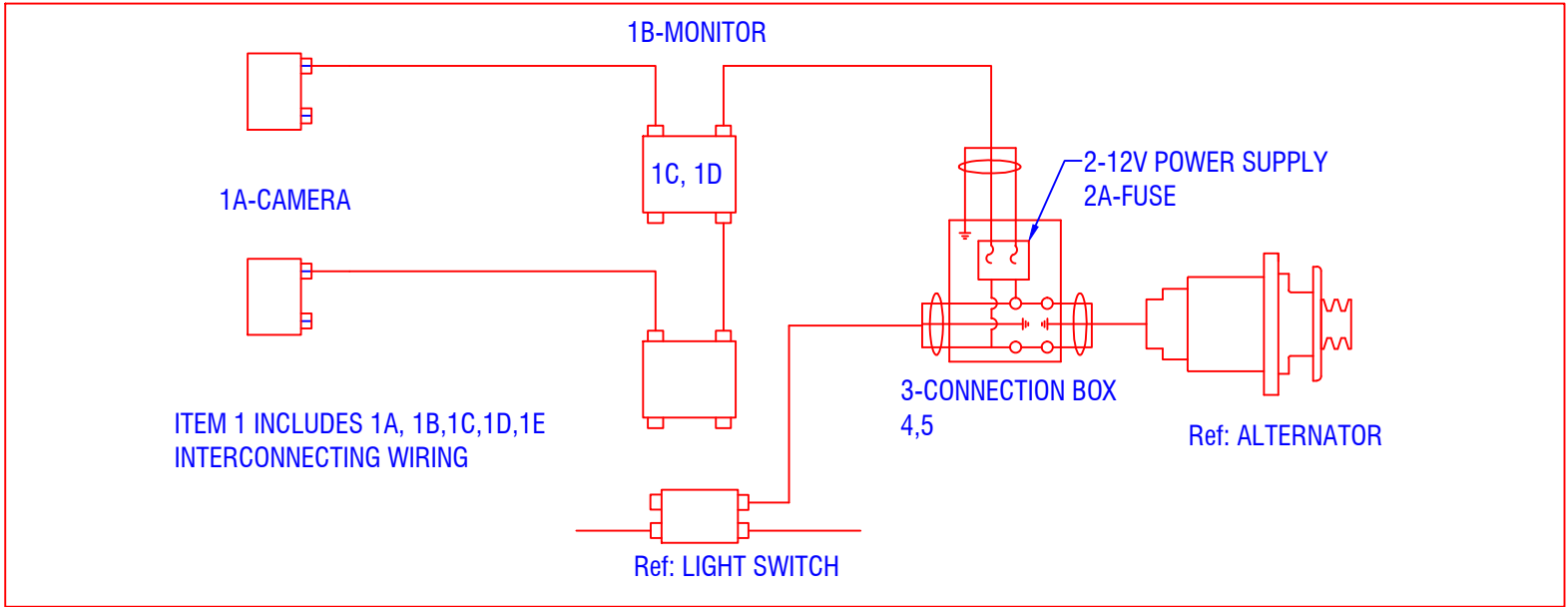

BILL of MATERIAL			
ITEM	QTY	PART NUMBER	DESCRIPTION
1	1	M261-529-01	CAMERA SYSTEM
1A	2	M261-529-06	CAMERA W/ HOUSING
1B	2	M261-529-05	MONITOR
1C	2	M261-529-02	FUSE, 1.6A
1D	2	M261-529-03	FUSE, 0.5A
1E	FT	M261-529-07	CABLE, CAMERA
2	1	M261-531-02	POWER SUPPLY
2A	2	M508-529-01	FUSE, 5A
3	1	M261-532-02	CONNECTION BOX
4	2	M261-504-01	PACKING GLAND, 5/8 90 DEG
5	5	M261-507-01	PLUG
		M261-533-01	CAMERA KIT

SECTION 7-14

TOLERANCES			
Linear unless noted			
Machined: ±0.005			
Fabricated: ±0.01			
Angular: ±1/2°			
Surface finish 125			
02	0315	RG	Add M261-529-07
01	0814	RG	S31-02 was 531-01, S32-02 was 532-01
REV	DATE	NAME	DESCRIPTION

DRY SYSTEMS TECHNOLOGIES
 10420 RISING COURT
 WOODRIDGE, IL 60517
 Phone: 630-427-2051 Fax: 630-427-1036
 E-Mail: eng@drysystemstech.com

DESCRIPTION CAMERA INSTALLATION		NO RECD
SCALE FULL	DATE Dec 2, 2013	DRAWN BY R GIBBS
MATERIAL See Detail Drawings		APPROVED BY
DRAWING NO M261-025-01		

