

DRY SYSTEMS TECHNOLOGIES®

PERMISSIBILITY CHECKLIST M272-001-01

Page 1 of 11

DST DRY SYSTEM® MODEL M272 MSHA APPROVED DIESEL POWER PACKAGE

94 HP MWM D916-6 DIESEL ENGINE

MSHA 7E-A001

www.drysystemstech.com

E-mail: eng@drysystemstech.com

DO NOT CHANGE WITHOUT MSHA APPROVAL

REVISION 00 * DATED JUNE 2004

DRY SYSTEMS TECHNOLOGIES®

www.drysystemstech.com E-mail: eng@drysystemstech.com

M272-001-01 * PERMISSIBILITY CHECKLIST * Page 2

MWM (Deutz) Diesel Engine

1. [] It has been determined that the area, in which tests are to be performed, is in **FRESH AIR**
2. [] The machine is equipped with a **MWM (Deutz) Model D916-6**, six-cylinder naturally aspirated diesel engine.

DST Air Intake System

The Air Intake System of this Power Package includes the following flameproof components: a MWM (Deutz) supplied intake manifold , an intake pipe, an intake flame arrester and an intake air shutdown valve with an actuating cylinder and mounting flanges, and an intake air cleaner.

Illustration No. 1 depicts the components of the air intake system.

3. [] All components appear to be the same as shown on Illustration No. 1. There is no visible damage, cracks, or dents on the components.

[WEEKLY]

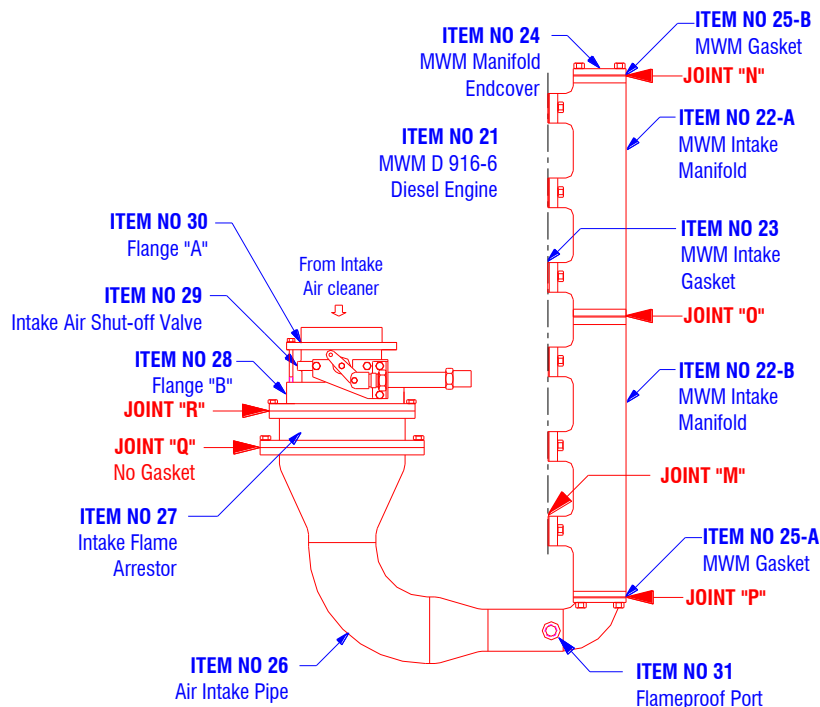

Illustration 1: Air Intake System

DO NOT CHANGE WITHOUT MSHA APPROVAL
REVISION 00 * DATED JUNE 2004

DRY SYSTEMS TECHNOLOGIES®

www.drysystemstech.com E-mail: eng@drysystemstech.com

M272-001-01 * PERMISSIBILITY CHECKLIST * Page 3

4. [] Item No. 22-A and No. 22-B is a two-piece MWM supplied intake manifold. Both manifold pieces are securely bolted together at Joint "O" and a gasket is installed between both pieces. Item No. 24 is a manifold end cover. The cover is securely attached to the intake manifold at Joint "N" and a MWM metal-clad gasket (Item No. 25-B) is installed between the components. All fasteners and locking devices are in place and tight.
[WEEKLY]
5. [] A 0.0015" feeler gauge cannot be inserted greater than 1/8" into the **Joint "N"** and **Joint "O"**.
[WEEKLY]
6. [] The two-piece intake manifold is securely attached to the MWM engine (Item No. 21) and six (6) MWM supplied metal-clad intake gaskets (Item No. 23) are installed between the components. All fasteners and locking devices are in place and tight.
[WEEKLY]
7. [] A 0.0015" feeler gauge cannot be inserted greater than 1/8" into the **Joint "M"**.
[WEEKLY]
8. [] Item No. 26 is an air intake pipe. It is securely attached to the intake manifold and a MWM metal-clad gasket (Item No. 25-A) is installed between the components. All fasteners and locking devices are in place and tight.
[WEEKLY]
9. [] A 0.0015" feeler gauge cannot be inserted greater than 1/8" into the **Joint "P"**.
[WEEKLY]
10. [] Item No. 27 is an intake flame arrestor. It is securely attached to the intake manifold and all fasteners and locking devices are in place and tight. No gasket is installed between the components.
[WEEKLY]
11. [] A 0.004" feeler gauge cannot be inserted into the **Joint "Q"**.
[WEEKLY]
12. [] Item No. 29 is an intake air shut-off valve. It is held between flange A (Item No. 30) and flange B (Item No. 28). The three components are securely attached to the flame arrestor and all fasteners and locking devices are in place and tight. No gasket is installed between the components and no check is required on **Joint "R"** as this is not a flame-proof joint.
[WEEKLY]
13. [] Once every twelve-months, remove the intake flame arrestor. The core of the flame arrestor consists of a 1.00" wide stainless steel crimped ribbon element. There is no apparent damage to the flame cell and a 0.018" plug gauge will not pass through any of the triangular openings. The proper procedure is outlined on Illustration 6. Reinstall the intake flame arrestor, and make sure all fasteners and locking devices are in place and tight.
[12 MONTH]

DO NOT CHANGE WITHOUT MSHA APPROVAL

REVISION 00 * DATED JUNE 2004

DRY SYSTEMS TECHNOLOGIES®

www.drysystemstech.com E-mail: eng@drysystemstech.com

M272-001-01 * PERMISSIBILITY CHECKLIST * Page 4

14. [] Item No. 31 is an optional flameproof port for monitoring the intake restriction. It is tightly installed into the intake pipe. A hose is connected to the flameproof port and the center plug is securely held in place with a retaining ring. If not installed, a pipe plug must be securely installed into the port.
[WEEKLY]
15. [] If an air compressor is installed, the air supply connection to the compressor must be located out-by (upstream) of the air intake flame arrestor and in-by (downstream) the intake air cleaner, unless the compressor is fitted with its own air intake cleaner.
[WEEKLY]
16. [] The intake air cleaner housing (not shown) is connected to the inlet of flange No. 30 with rubber hoses, elbows and piping. The hoses must be securely attached with hose clamps and must have no damage or leakage.
[WEEKLY]

DST Exhaust System

The Exhaust System of this Power Package includes the following flameproof components: a modified MWM supplied water-cooled engine exhaust manifold, a water-cooled manifold outlet elbow, a water-cooled bellows assembly, a water-cooled catalyst, a second water-cooled elbow, a heat exchanger with a water-cooled inlet/outlet box, an exhaust outlet pipe, an exhaust flame arrestor, and a DPM filter housing with a disposable paper element DPM filter.

Illustrations No. 2, No. 3 and No. 4 on the following pages depict the components of the exhaust system.

17. [] Illustration No. 2 depicts the first section of the MWM and DST exhaust system components that are located between the exhaust ports of the MWM diesel engine and the inlet of the manifold outlet elbow. All components appear as depicted and there is no visible damage, cracks or dents on the components.
[WEEKLY]

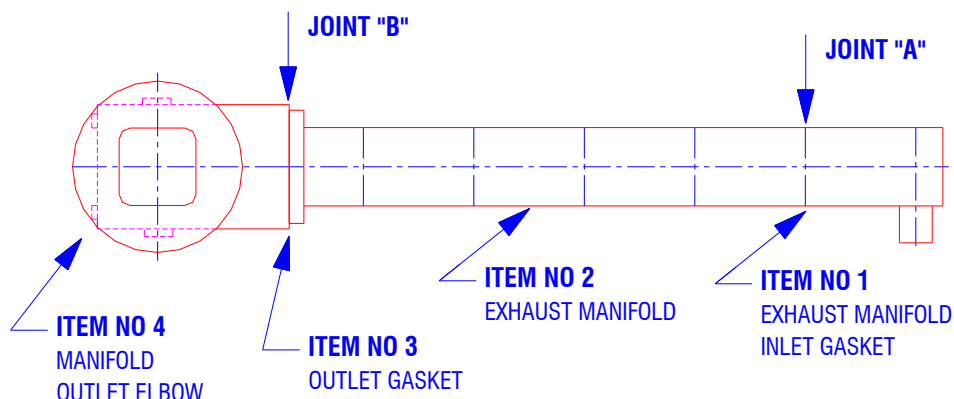

Illustration 2: Exhaust System from Manifold to Manifold Outlet Elbow

DRY SYSTEMS TECHNOLOGIES®

www.drysystemstech.com E-mail: eng@drysystemstech.com

M272-001-01 * PERMISSIBILITY CHECKLIST * Page 5

18. [] Item No. 2 is a MWM supplied water cooled exhaust manifold. It is securely attached to the exhaust ports of the MWM diesel engine. Items No. 1 are six MWM supplied metal-clad gaskets installed between the components. All fasteners and locking devices are in place and tight.
[WEEKLY]
19. [] A 0.0015" feeler gauge cannot be inserted greater than 1/8" into the **Joint "A"**.
[WEEKLY]
20. [] Item No. 4 is a water cooled exhaust manifold outlet elbow. It is securely attached to the outlet of the exhaust manifold. Item No. 3 is a MWM supplied metal-clad gasket installed between the components. All fasteners and locking devices are in place and tight.
[WEEKLY]
21. [] A 0.0015" feeler gauge cannot be inserted greater than 1/8" into the **Joint "B"**.
[WEEKLY]
22. [] Illustration No. 3 depicts the second section of the DST exhaust system components that are located between the manifold outlet elbow and the inlet of the inlet-outlet box. All components appear as depicted and there is no visible damage, cracks or dents on the components.
[WEEKLY]

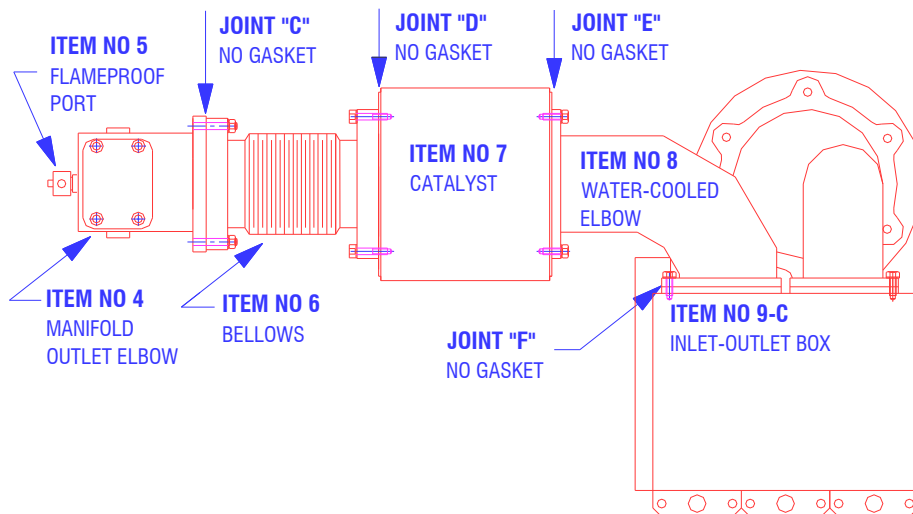

Illustration 3: Exhaust System from Manifold Outlet Elbow to Inlet-Outlet Box

23. [] Item No. 5 is an optional flameproof port for monitoring the total backpressure and sampling of the untreated (engine-out) carbon monoxide. It is tightly installed into the side port of the manifold outlet elbow. A hose is connected to the flameproof port and the center plug is securely held with a retaining ring. If not installed, a pipe plug must be securely installed into the port.
[WEEKLY]

DO NOT CHANGE WITHOUT MSHA APPROVAL
REVISION 00 * DATED JUNE 2004

DRY SYSTEMS TECHNOLOGIES®

www.drysystemstech.com E-mail: eng@drysystemstech.com

M272-001-01 * PERMISSIBILITY CHECKLIST * Page 6

24. [] Item No. 6 is a water-cooled bellows assembly. It is securely attached to the outlet flange of the manifold outlet elbow and all fasteners and locking devices are in place and tight. No gasket is used between the components.
The bellows convolutes are not cracked or damaged and there is no indication of any coolant leaks.
[WEEKLY]
25. [] A 0.004" feeler gauge cannot be inserted into the **Joint "C"**.
[WEEKLY]
26. [] Check the bellows for damage. If damage to the convolutes or leaks to the water-cooled bellows are detected, replace the complete bellows assembly. Every 24 months, or 5,000 operating hours, remove and inspect the bellows assembly regardless of its apparent external condition. If there is damage to the inside convolutes or if leaks inside the water-cooled bellows are detected, replace the complete bellows assembly. When re-installing the original or a replacement bellows assembly, all fasteners and locking devices are in place and tight on both flanges. Check the flame gap on **Joints "C" and "D"** as described under No. 25 and No. 28.
[SEE NOTE]
27. [] Item No. 7 is a water-cooled catalyst assembly. It is securely attached to the outlet flange of the bellows and all fasteners and locking devices are in place and tight. No gasket is installed between the components.
[WEEKLY]
28. [] A 0.004" feeler gauge cannot be inserted into the **Joint "D"**.
[WEEKLY]
29. [] Item No. 8 is a water-cooled elbow. It is securely attached to the outlet of the catalyst and all fasteners and locking devices are in place and tight. No gasket is installed between the components.
[WEEKLY]
30. [] A 0.004" feeler gauge cannot be inserted into the **Joint "E"**.
[WEEKLY]
31. [] Item No. 9-C is an inlet flange of the inlet-outlet box of the heat exchanger. The water-cooled elbow is securely attached to the inlet flange and all fasteners and locking devices are in place and tight. No gasket is installed between components.
[WEEKLY]
32. [] A 0.004" feeler gauge cannot be inserted into the **Joint "F"**.
[WEEKLY]
33. [] Illustration No. 4 depicts the third section of the exhaust system components that are located between the heat exchanger and the final exhaust pipe. All components appear as depicted and there is no visible damage, cracks or dents on the components.
[WEEKLY]

DRY SYSTEMS TECHNOLOGIES®

www.drysystemstech.com E-mail: eng@drysystemstech.com

M272-001-01 * PERMISSIBILITY CHECKLIST * Page 7

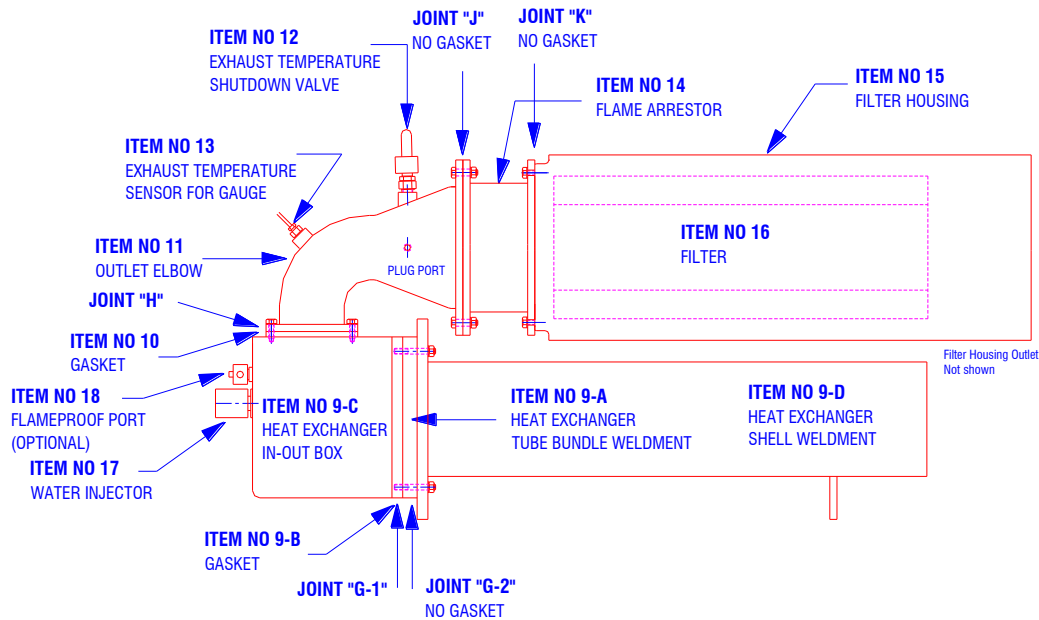

Illustration No 4: Exhaust System from Inlet-Outlet Box to Filter Housing

34. [] Item No. 9-A is a heat exchanger tube bundle weldment. Only the flange is visible. The inlet-outlet box is securely attached to the inlet of the the heat exchanger. Item No. 9-B is a copper gasket. It is installed between the flanges of the inlet-outlet box and the tube bundle. Item No. 9-D is the heat exchanger shell weldment. It is securely attached to the other end of the tube bundle flange of the heat exchanger. No gasket is installed between the two components. The three flanges are securely tightened together and all fasteners and locking devices are in place and tight.
- [WEEKLY]
35. [] A 0.0015" feeler gauge cannot be inserted greater than 1/8" into the **Joint "G-1"**. **Joint "G-2"** is not considered flameproof and requires no check.
- [WEEKLY]
36. [] Two OPTIONAL flameproof ports (Item No.18) may be installed into the end of the inlet-outlet box. These OPTIONAL ports may be used in conjunction with an OPTIONAL pressure differential gauge monitoring the heat exchanger. If installed, check that they are tightly installed into the end ports of the inlet-outlet box. A hose is connected to each flameproof port and the center plug is securely held with a retaining ring. If not installed, pipe plugs must be securely installed into the ports.
- [WEEKLY]

DO NOT CHANGE WITHOUT MSHA APPROVAL
REVISION 00 * DATED JUNE 2004

DRY SYSTEMS TECHNOLOGIES®

www.drysystemstech.com E-mail: eng@drysystemstech.com

M272-001-01 * PERMISSIBILITY CHECKLIST * Page 8

37. [] Item No.11 is the exhaust outlet elbow. It is securely attached to the outlet flange of the inlet-outlet box and all fasteners and locking devices are in place and tight. Item No.10 is a copper gasket. It is installed between the inlet-outlet box and the exhaust outlet elbow.
[WEEKLY]
38. [] A 0.0015" feeler gauge cannot be inserted greater than 1/8" into the **Joint "H"**.
[WEEKLY]
39. [] Item No.17 is a flameproof water injector for the on-board cleaning system. It is tightly installed into the 3/4" pipe thread connection on the end of the inlet side of the heat exchanger inlet-outlet box.
[WEEKLY]
40. [] Item No.12 is an exhaust temperature shutdown valve. It is tightly installed into the pipe threaded connection on top of the exhaust outlet elbow.
[WEEKLY]
41. [] Item No.13 is an optional exhaust temperature sensor for the gauge in the operator's cab. It is tightly installed into the pipe thread at the elbow section of the exhaust outlet elbow. If a sensor is not installed, a pipe plug must be installed securely into the port. There is a second pipe threaded connection on the side of the elbow. A pipe plug must be installed securely into the port.
[WEEKLY]
42. [] Item No.14 is an exhaust flame arrester. It is securely attached to the outlet flange of the exhaust outlet elbow and all fasteners and locking devices are in place and tight. No gasket is installed between the components.
[WEEKLY]
43. [] A 0.004" feeler gauge cannot be inserted into the **Joint "J"**.
[WEEKLY]
44. [] Once every twelve-months, remove the exhaust flame arrester. The flame arrester core consists of a 4" wide stainless steel crimped ribbon element. There is no apparent damage and a 0.038" plug gauge will not pass through any of the triangular openings. The procedure is outlined on Illustration 6. Reinstall the exhaust flame arrester, and make sure all fasteners and locking devices are in place and tight.
[12 MONTHS]
45. [] Item No.15 is an exhaust particulate filter housing. It is securely attached to the exhaust flame arrester and all fasteners and locking devices are in place and tight. There is no gasket between the components and the joint is not considered flame proof. No check is necessary on **Joint "K"**.
[WEEKLY]
46. [] Item No.16 is a 10" DPM filter element and **must be marked "DST M40"** on its end.
[WEEKLY]

DO NOT CHANGE WITHOUT MSHA APPROVAL
REVISION 00 * DATED JUNE 2004

47. [] Remove the exhaust particulate filter from the exhaust filter housing. Avoid direct contact with diesel soot. Visually inspect the outlet side of the flame arrestor from the filter housing. There is no apparent damage to the crimped ribbon core of the exhaust flame arrestor. Visually inspect the exhaust particulate filter element for damage or leaks. Reinstall the exhaust particulate filter into the exhaust filter housing, or replace it with a new DST exhaust particulate filter if necessary.

[WEEKLY]

THE USE OF AFTERMARKET FILTERS WILL VOID THE MSHA APPROVAL.

DST Shut Down Devices

48. [] As shown on Illustration 5, two (2) safety shut-down valves are part of the DST Dry System: Item No.S1 is an exhaust temperature shutdown valve and is located on the exhaust outlet elbow.

[WEEKLY]

Item No.S2 is a high coolant temperature shutdown valve and is located in the junction box in the coolant return line. Both valves are tightly installed and connected to the safety shut-down system.

49. Both high temperature safety shutdown valves are to be removed and tested every 6 months as described below:

[6 MONTHS]

- a. [] Remove the high coolant temperature shutdown valve together with the well. Plug the opening in the junction box with a pipe plug while performing this test. Do not separate the valve from the well. Place the high coolant temperature shutdown valve into a 50-50 water & ethylene glycol mixture and slowly heat the mixture. The high coolant temperature shutdown valve must **open at or before 205° F and shut down the engine.**

- b. [] Remove the exhaust temperature shutdown valve with an integral well. Do not separate the valve from the well. Close the port in the exhaust elbow with a pipe plug while performing this test. Place the exhaust temperature shutdown valve and well into a non-flammable liquid, such as non-flammable transmission fluid or non-flammable hydraulic fluid, and slowly heat the fluid. The exhaust gas temperature shutdown valve must **open at or before 275° F and shut down the engine.**

OPTIONAL: This method of testing is intended to expose the exhaust temperature shutdown valve to the uncooled hot exhaust gases of the system instead of hot fluid. Remove hoses from water cleaner injector. Remove injector from heat exchanger inlet/outlet box. Remove the exhaust temperature shutdown valve with an integral well. Do not separate the valve from the well. Close the port in the exhaust elbow with a pipe plug while performing this test. Assemble a standpipe from pipe fittings. This standpipe should be threaded into the water injector location. Suspend the exhaust temperature shutdown valve with the hose attached into this standpipe. A

DO NOT CHANGE WITHOUT MSHA APPROVAL

REVISION 00 * DATED JUNE 2004

DRY SYSTEMS TECHNOLOGIES®

www.drysystemstech.com E-mail: eng@drysystemstech.com

M272-001-01 * PERMISSIBILITY CHECKLIST * Page 10

temperature measurement device such as a thermocouple or thermometer should also be placed in the standpipe. Operate the engine at moderate speed to subject the high exhaust gas temperature shutdown valve to the uncooled gases. Monitor the temperature. The high exhaust gas temperature shutdown valve must **open between 275° F and 302° F and the engine must shut down before exceeding 302° F.**

- c. [] Reinstall both temperature shutdown valves into their proper locations. Make sure that both valves are tightly installed and re-connected to the safety shut-down system.
50. [] With the engine at idle speed of 650 RPM, activate the emergency shutdown valve. Upon activation, the intake air shutoff valve must operate immediately and the **engine must shut down within 15 seconds.**
- [WEEKLY]

System Operation

51. [] With the throttle pedal fully depressed, the transmission in neutral and all accessories disengaged, the engine speed indicated on the gauge in the operators cab does not exceed 2,450 RPM
- [WEEKLY]
52. [] Run engine at high idle speed of 2,350-2,450 RPM. The total intake restriction shown on the gauge in the operator's cab must not exceed 20 inches H₂O and the total exhaust restriction shown on the gauge in the operator's cab must not exceed 40 inches.
- [WEEKLY]

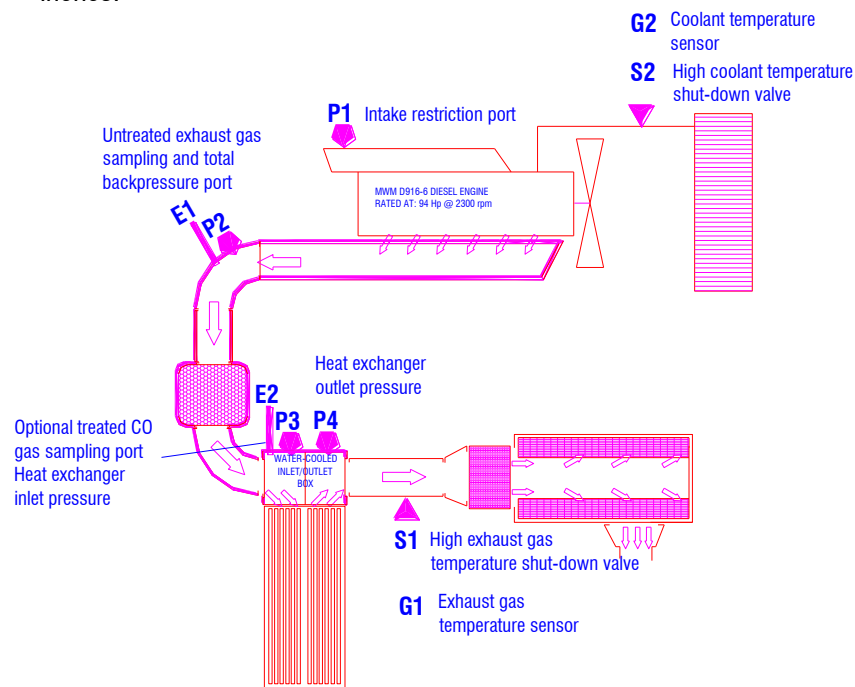

Illustration No 5: Location of Pressure and Temperature Sensors

DO NOT CHANGE WITHOUT MSHA APPROVAL

REVISION 00 * DATED JUNE 2004

Flame Arrestor Inspection Procedure

1. Remove the Flame Arrestor Assembly
2. Place the Flame Arrestor Assembly on a flat surface with a contrasting background under the flame arrestor, such as brattice cloth or clean white cloth.
3. Adequate lighting is required. Cap lamp lighting is not sufficient.
4. Visually inspect each side of the Flame Arrestor for openings or spaces obviously greater than the triangular openings of the core.
5. Visually inspect each side of the core for places where the windings of the flame arrestor core appear to be separated such that gaps can be seen. If such gaps exist, they must be checked as following:
 - a.) The only measuring tool considered acceptable for performing this evaluation is a 0.038 inch or 0.018 inch diameter calibrated plug gauge, sometimes called wire gauge. The Plug Gauge is to be mounted in a Gauge Holder must project at least 1.0 inch out of the end.
 - b.) Grasp the gauge holder lightly between the index finger and the thumb. Place the wire tip at the point in question, making sure the plug gauge is vertical. Using only the weight of the gauge and holder, see if it will enter the apparent gap. Do not attempt to wiggle or push the gauge through the opening.
 - c.) If the plug gauge enters the opening, the flame arrestor core must not be used on permissible equipment.
6. Visually inspect the triangles in the flame arrestor core (both sides) for triangles that appear to be larger than the rest. If such conditions exist, these openings must be checked as previously described in section 5 a, b and c.
7. Finally, if the flame arrestor core passes all the above evaluations, a final check should be performed on at least 5 randomly selected triangles on each side of the core with the procedure described in section 5 a, b and c. In performing this check, the tip of the plug gauge must be placed against a specific triangular opening. If this special care is not taken, the evaluation will be invalid.

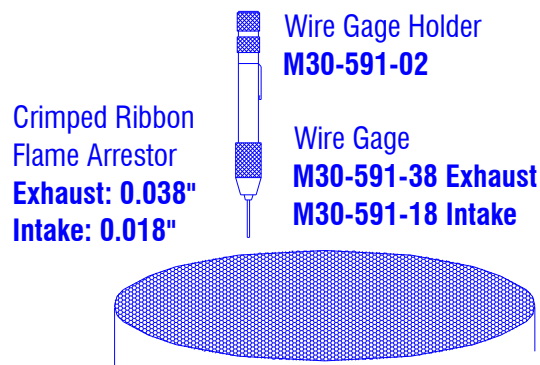

Illustration No 6: Flame Arrestor Checking Procedure
This Permissibility Checklist contains 52 Items on 11 Pages with 6 Illustrations.