

DRY SYSTEMS TECHNOLOGIES®

MACHINE PERMISSIBILITY CHECKLIST

Make and model No: DST-H25XSH

Engine: Cummins C8.3, Approval: 07-EPA040001, 07-EPA120001,
07-EPA140001

Machine Serial Number: _____

MSHA Approval Number: _____

Date of Examination: _____

Machine Type: _____

Examination Conducted By: _____

E-mail: eng@drysystemstech.com Web: www.drysystemstech.com

DRY SYSTEMS TECHNOLOGIES®

E-mail: eng@drysystemstech.com Web: www.drysystemstech.com

If an MSHA Part 36 approval plate has been affixed to this machine, it must meet the requirements of Part 36, Title 30, Code of Federal Regulations. It is the responsibility of the mine operator to ensure that this machine is maintained in permissible condition in accordance with this checklist.

- For a complete permissibility evaluation, this checklist must be used in conjunction with a Power System Checklist, M255-001-01, and Electrical System Checklist, M261-008-01.
- Due to Braking Capability Limitations, this machine shall not be operated on grades greater than 20%.
- The approval plate specifies a ventilation rate of 13500 cfm for Part 7 engine approval nos. 07-EPA040001 or 07-EPA120001. 10000 cfm for Part 7 engine approval no. 07-EPA140001.

The component and function checks in this document that are designated as “WEEKLY” must be performed during each weekly examination in accordance with 30 CFR, Section 75.1914.

ALL INSPECTIONS AND TESTS SHALL BE PERFORMED IN FRESH AIR.

A. Fuel System

- Weekly 1. [] There are no fuel leaks.
- Weekly 2. [] The fuel filler cap is vented and the vent is not plugged.
- Weekly 3. [] The fuel filler cap is self-closing and is attached to the tank in a manner which will prevent loss during refueling.

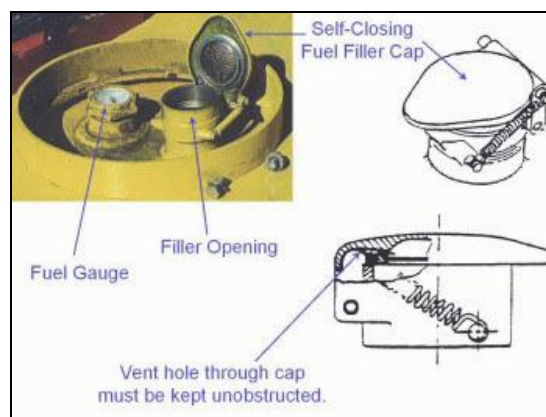

- Weekly 4. [] Auxiliary fuel tank capacity has not been added to the vehicle.
- Weekly 5. [] Fuel filters are properly installed and are not damaged.

DRY SYSTEMS TECHNOLOGIES®

E-mail: eng@drysystemstech.com Web: www.drysystemstech.com

Weekly

6. The fuel injection rate adjustment mechanism and the engine governor setting are locked and sealed.

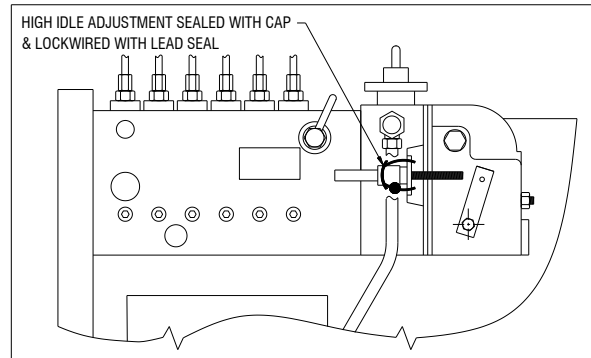

Weekly

7. The fuel shutoff valve in the fuel supply line is operable.

Weekly

8. The drain plug in the fuel tank is locked in position.

Weekly

9. Fuel lines are either steel-wire reinforced, fire-resistant synthetic elastomer-covered hose suitable for use with diesel fuel, or metal.

Weekly

10. Fuel lines are not routed near or connected to hot exhaust components and are protected from external damage.

Weekly

11. Fuel lines are secured.

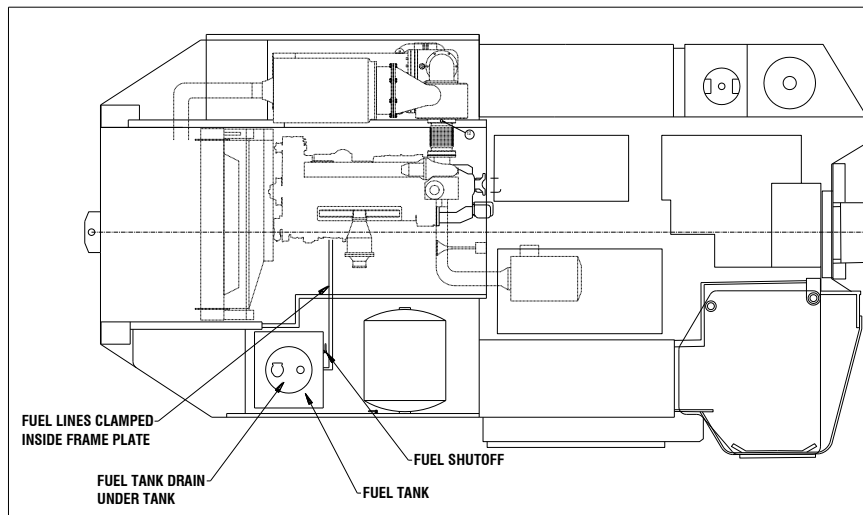

B. Braking System

Warning Brake tests are to be conducted on a relatively level surface, away from traffic areas where other machines or persons may be moving about. Consider the possible consequences of testing a machine with braking inadequacies, and select an area where the test machine would not cause an accident due to these inadequacies.

NOTE: These tests must insure service and parking brake capability equal to or greater than the maximum specified gradeability of the machine.

- Weekly 1. [] Service Brake Test.
- a. With the engine operating and the machine stationary, apply the service brake.
 - b. Release all other brakes.
 - c. Place the transmission gear selector in second gear and the directional control selector in forward or reverse.
 - d. Depress the accelerator to full throttle, allowing the engine to put the transmission torque converter into a stall condition.

If the service brake is operating satisfactorily, the unit will not move when the above procedure is followed. If movement is detected, the service brake must be repaired or adjusted.

- Weekly 2. [] Parking Brake Test.
- a. With the engine operating and the machine stationary, apply the parking brake.
 - b. Release all other brakes.
 - c. Place the transmission gear selector in second gear and the directional control selector in forward or reverse.
 - d. Depress the transmission declutch valve and hold during the test.
 - e. Depress the accelerator to full throttle, allowing the engine to put the transmission torque converter into a stall condition.

If the parking brake is operating satisfactorily, the unit will not move when the above procedure is followed. If movement is detected, the parking brake must be repaired or adjusted.

DRY SYSTEMS TECHNOLOGIES®

E-mail: eng@drysystemstech.com Web: www.drysystemstech.com

Miscellaneous

- Weekly 1. The vehicle is equipped with at least one dry chemical fire extinguisher with a minimum of a 10A:60B:C NFPA rating. All fire extinguishers are fully charged.
- *2. The fire suppression system is tested and maintained in accordance with its manufacturer's recommended inspection and maintenance program.
- Weekly *3. The fire suppression system is operable as determined by the following checks:
- a. Note general appearance of system components for mechanical damage or corrosion.
 - b. Check hose fittings and nozzles for mechanical damage and cuts.
 - c. Nozzles are protected against the entrance of foreign materials such as mud, coal dust or rockdust. Check nozzle openings; slot on nozzles should be closed with silicone grease or covered with a plastic blow off cap.
 - d. The lead or wire seals are installed on all manual actuators. (If missing, refer to fire suppression system manufacturer's inspection manual for inspecting actuator gas cartridges.)
- Weekly 4. The machine has a legible MSHA Part 36 approval plate attached to it in the operator's compartment.
- Weekly 5. The machine is equipped with a neutral start and it is functioning properly. There is no tendency for the vehicle to move or take up driveline slack when the engine is started with the transmission selector in the forward or reverse position.

*Fire suppression system is optional for machines operating in metal/nonmetal mines.