

CONFIDENTIAL & PROPRIETARY
 All data contained in this document is sole property
 of DRY SYSTEMS TECHNOLOGIES and is considered
 confidential and proprietary.
 This document may not be reproduced, released to
 third parties, or used for purposes other than for which
 it was furnished, without express written consent of
 DRY SYSTEMS TECHNOLOGIES.
 This document remains property of DRY SYSTEMS
 TECHNOLOGIES and must be returned upon request.

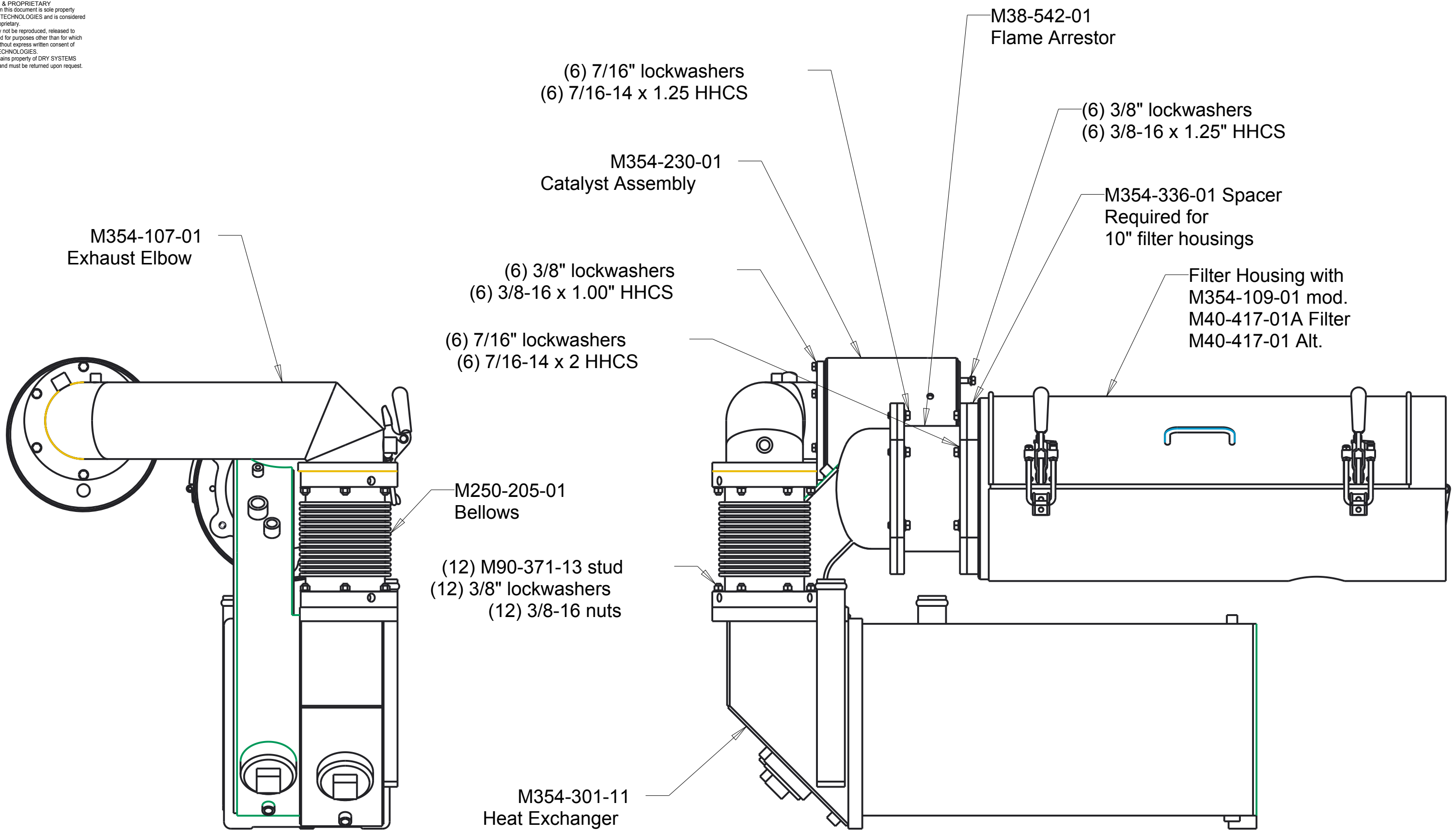

DO NOT CHANGE DRAWING WITHOUT MSHA APPROVAL

TOLERANCES Linear unless noted Machined: ±0.005 Fabricated: ±0.01 Angular: ± 1/2° Surface finish 125 Third angle projection	REV	DATE	NAME	DESCRIPTION	DRY SYSTEMS TECHNOLOGIES 10420 RISING COURT WOODRIDGE, IL 60517 Phone: 630-427-2051 Fax: 630-427-1036 E-Mail: eng@drysystemstech.com	Description: Exhaust Assembly, N45 RH No. Reqd:		
	Scale: 0.150		Date: 22 Oct 2014	Drawn By: Brian Wiltjer		Approved By:		
	Material:		Drawing No: M354-102-01					
	Sheet:		1/1					