

**DRY SYSTEMS TECHNOLOGIES®**

**POWER PACKAGE CHECKLIST**  
**M389-003-01**

Page 1 of 14

**DST DRY SYSTEM®**  
**MODEL M389**  
**DIESEL POWER PACKAGE**

**MITSUBISHI S4S-VSCA DIESEL ENGINE**

[www.drysystemstech.com](http://www.drysystemstech.com)

E-mail: [eng@drysystemstech.com](mailto:eng@drysystemstech.com)

## **Mitsubishi S4S-VSCA Diesel Engine**

1. [ ] It has been determined that the area, in which tests are to be performed, is in **FRESH AIR**.
2. [ ] The machine is equipped with a **Mitsubishi S4S-VSCA**, four-cylinder diesel engine.

## **Air Intake System**

The Air Intake System of this Power Package includes the following components: an intake manifold with an inlet gasket installed between the engine and the manifold, and a flame arrestor attached to the manifold inlet with a gasket installed between both components.

All additional components located upstream of the intake flame arrestor, including an adapter, a butterfly valve, an intake air cleaner and associated pipes, hoses and clamps do not need to be checked.

3. [ ] **Illustration No. 1** depicts the air intake assembly. All components appear as depicted and there is no visible damage, cracks or dents on the components.  
*[WEEKLY]*
4. [ ] Item No. 1 is a pipe plug. It is installed into the engine intake manifold and is tight.  
*[WEEKLY]*
5. [ ] Item No. 2 is a gasket. It is securely installed between the inlet port of the diesel engine and the intake manifold.  
*[WEEKLY]*
6. [ ] Item No. 3 is an intake manifold. It is securely attached to the air intake port of the Mitsubishi S4S engine. All fasteners are in place and tight.  
*[WEEKLY]*
7. [ ] A 0.0015" feeler gauge cannot be inserted greater than 1/8" into **Joint "A"**.  
*[WEEKLY]*
8. [ ] Item No. 4 is a pipe plug. It is installed into the flame arrestor and is tight.  
*[WEEKLY]*
9. [ ] Item No. 5 is a flameproof port this is installed in the flame arrestor. This port is used to monitor the air intake restriction. Check that it is tightly installed. A hose is connected, and the center plug is securely held in place with a retaining ring.  
*[WEEKLY]*

10. [ ]  
[WEEKLY]

Item No. 6 is a gasket. It is securely installed between the inlet port of the intake manifold and the flame arrester. An additional gasket is secured between the adapter and the intake to the flame arrester.

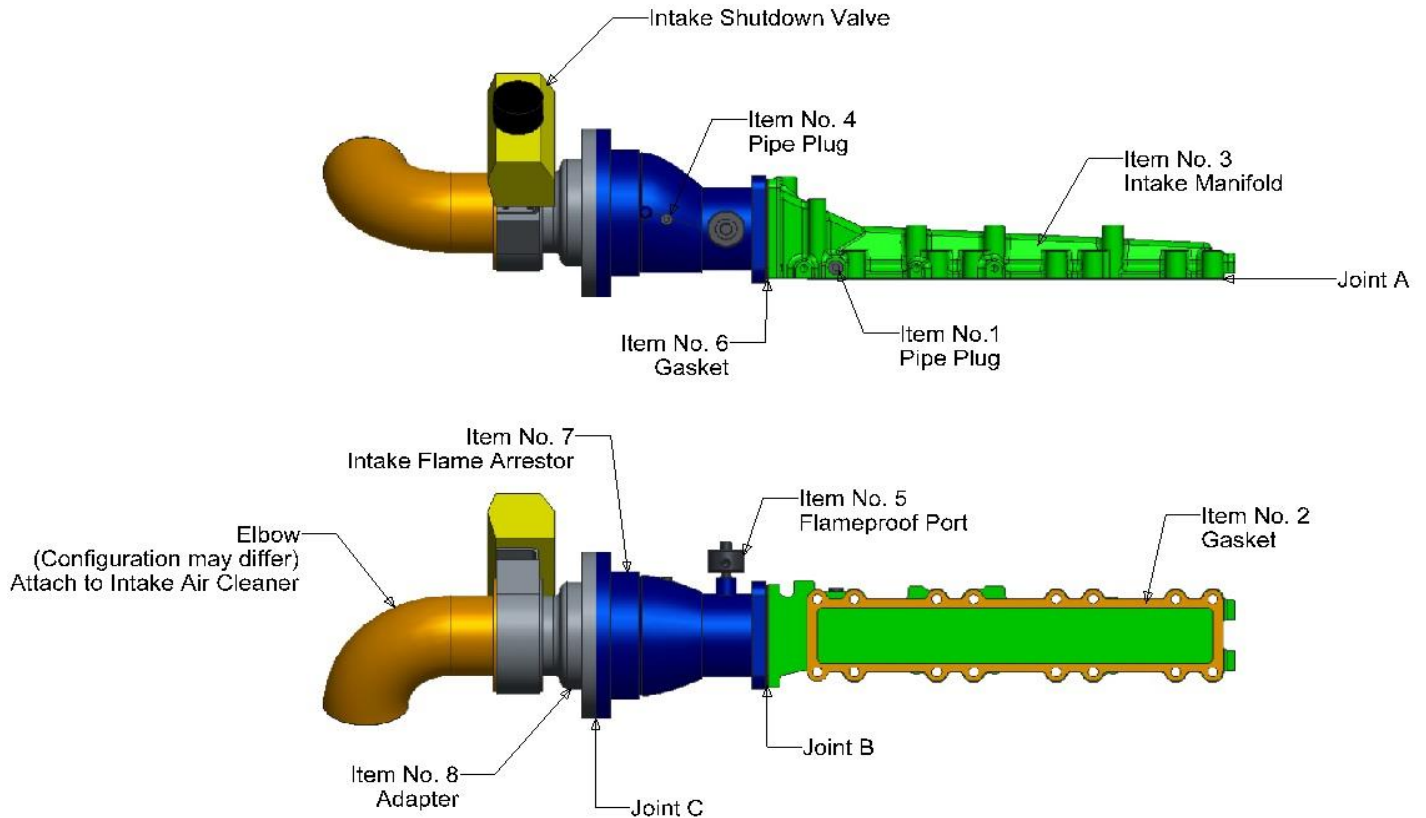

**Illustration No. 1: Air Intake Assembly**

11. [ ]  
[WEEKLY]

Item No. 7 is an intake flame arrester. It is securely attached to the air intake port of the intake manifold. All fasteners and locking devices are in place and tight.

12. [ ]  
[WEEKLY]

A 0.0015" feeler gauge cannot be inserted greater than 1/8" into **Joint "B"**.

13. [ ]  
[12 MONTHS] Once every twelve-months, remove the intake flame arrestor. The flame arrestor core consists of a 1" wide stainless steel crimped ribbon element. There is no apparent damage and a 0.018" plug gauge will not pass through any of the triangular openings. The procedure is outlined on Illustration No. 8. When re-installing the flame arrestor & intake assembly, all fasteners and locking devices are in place and tight on both flanges. A 0.0015" feeler gauge cannot be inserted greater than 1/8" into **Joint "B"**. No further check is necessary on **Joint "C"**.

14. [ ]  
[WEEKLY] Item No. 8 is an adapter. It is attached to the inlet of the flame arrestor.

No check is required on **Joint "C"**. check is required on the air intake hoses, pipes, charge air cooler, or other components located upstream of the flame arrestor.

## **Exhaust System**

The Exhaust System of this Power Package includes the following components: a water-cooled metallic surface insulation installed on the exhaust side of the engine, a water-cooled exhaust manifold with copper gaskets installed at its inlet, a water-cooled catalyst, two water-cooled elbows, a water-cooled bellows assembly, a water-cooled heat exchanger with inlet/outlet box, an exhaust flame arrestor, and a DPM filter housing with a disposable DST low temperature filter element.

15. [ ]  
[WEEKLY] **Illustration No. 2** depicts the manifold section of the exhaust system located between the exhaust ports of the diesel engine and the water-cooled elbow. All components appear as depicted and there is no visible damage, cracks, or dents on the components.

16. [ ]  
[WEEKLY] Item No. 9 is water-cooled metallic insulation. It is installed on the exhaust side of the cylinder head. There is no apparent damage.

17. [ ]  
[WEEKLY] Items No. 10 are four copper gaskets. They are installed between the exhaust ports of the diesel engine and the exhaust manifold.

18. [ ]  
[WEEKLY] Items No. 11 is a water-cooled exhaust manifold. It is securely attached to the exhaust ports of the Mitsubishi diesel engine. All fasteners are in place and tight.

19. [ ]  
[WEEKLY] A 0.0015" feeler gauge cannot be inserted greater than 1/8" into the **Joint "D"**.

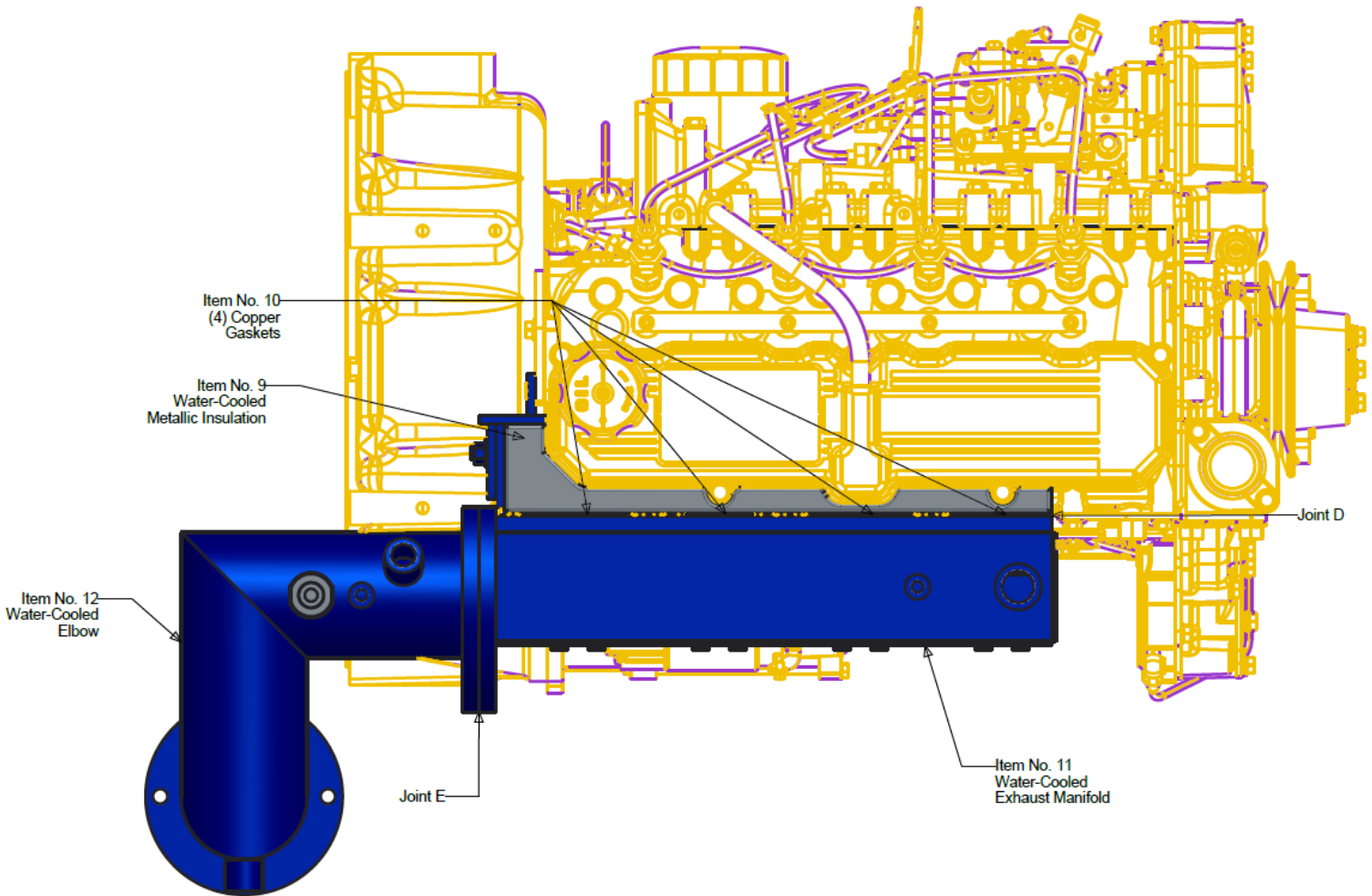

**Illustration No. 2: Exhaust Assembly "A"**

20. [ ] Item No. 12 is a water-cooled elbow. It is securely attached to the outlet of the exhaust  
[WEEKLY] manifold. No gasket is installed and all fasteners and locking devices are in place and tight.
21. [ ] A 0.004" feeler gauge cannot be inserted into **Joint "E"**.  
[WEEKLY]

# DRY SYSTEMS TECHNOLOGIES®

[www.drysystemstech.com](http://www.drysystemstech.com) E-mail: [eng@drysystemstech.com](mailto:eng@drysystemstech.com)

## M389-003-01 \* POWER PACKAGE CHECKLIST \* Page 6

22. [ ]  
[WEEKLY] Item No. 13 is a flameproof port installed into the water-cooled exhaust elbow for monitoring total backpressure and sampling untreated (engine-out) carbon monoxide. A hose is connected to the flameproof port and the center plug is securely held with a retaining ring.
23. [ ]  
[WEEKLY] A 0.004" feeler gauge cannot be inserted into the **Joint "F"**.
24. [ ]  
[WEEKLY] Item No. 14 is a water-cooled catalyst. It is securely attached to the outlet of the water-cooled elbow. No gasket is installed and all fasteners and locking devices are in place and tight.
25. [ ]  
[WEEKLY] A 0.004" feeler gauge cannot be inserted into the **Joint "G"**.
26. [ ]  
[WEEKLY] **Illustration No. 3** depicts the exhaust system components located between the water-cooled exhaust manifold and the water-cooled bellows. All components appear as depicted and there is no visible damage, cracks, or dents on the components.

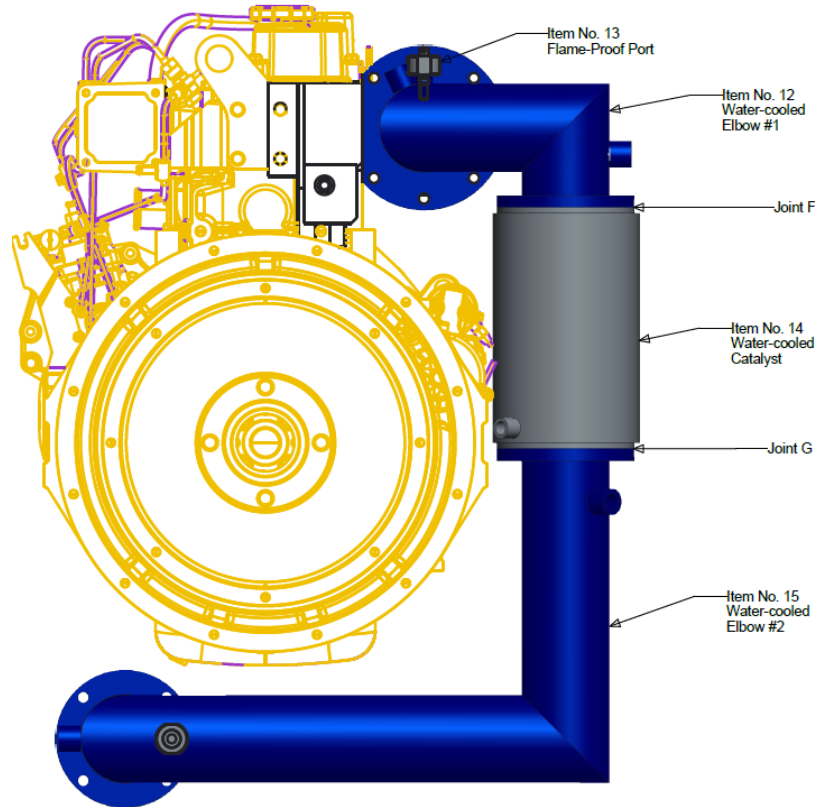

**Illustration No. 3: Exhaust Assembly "B"**

# DRY SYSTEMS TECHNOLOGIES®

[www.drysystemstech.com](http://www.drysystemstech.com) E-mail: [eng@drysystemstech.com](mailto:eng@drysystemstech.com)

## M389-003-01 \* POWER PACKAGE CHECKLIST \* Page 7

27. [ ] Item No. 15 is a water-cooled elbow. It is securely attached to the outlet of the catalyst.  
[WEEKLY] No gasket is installed and all fasteners and locking devices are in place and tight.
28. [ ] **Illustration No. 4** depicts the exhaust system components located from the water-cooled  
[WEEKLY] elbow to the heat-exchanger. All components appear as depicted and there is no visible damage, cracks, or dents on the components.

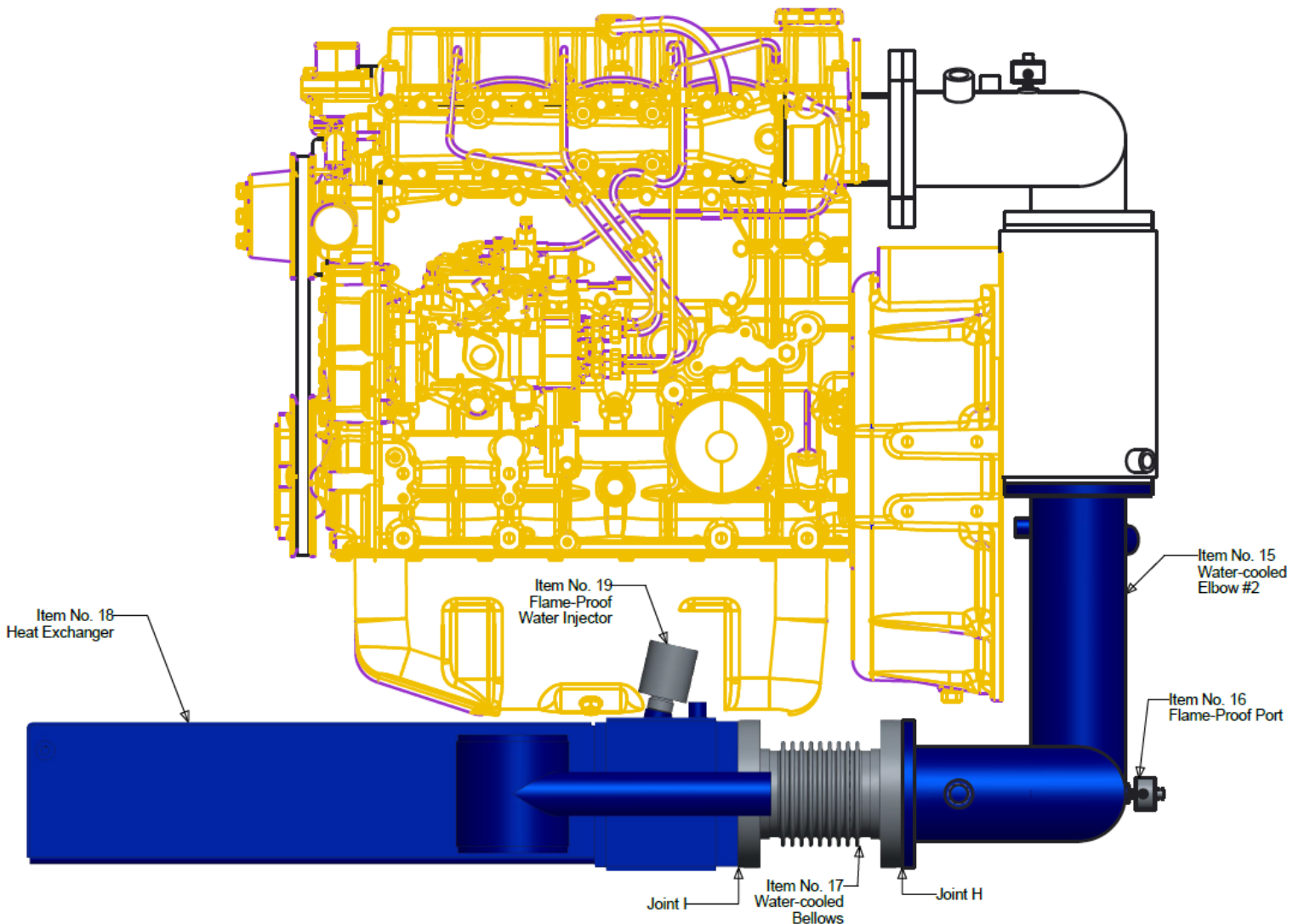

**Illustration No. 4: Exhaust Assembly "C"**

# DRY SYSTEMS TECHNOLOGIES®

[www.drysystemstech.com](http://www.drysystemstech.com) E-mail: [eng@drysystemstech.com](mailto:eng@drysystemstech.com)

## M389-003-01 \* POWER PACKAGE CHECKLIST \* Page 8

---

29. [ ] Item No. 16 is an optional flameproof port installed into the water-cooled elbow for sampling treated carbon monoxide. If installed in conjunction with a pressure differential gauge, it can be used to monitor heat-exchanger pressures. If installed, check that the flameproof port is tightly installed into the water-cooled elbow. If the flameproof port is not installed, a pipe plug is securely installed into the port.  
*[WEEKLY]*
30. [ ] Item No. 17 is a water-cooled bellows assembly. It is securely attached to the outlet of the water-cooled elbow. No gasket is installed and all fasteners and locking devices are in place and tight. The bellows convolutes are not cracked or damaged and there is no indication of any coolant leak.  
*[WEEKLY]*
31. [ ] A 0.004" feeler gauge cannot be inserted into **Joint "H"**.  
*[WEEKLY]*
32. [ ] Check the bellows for external damage. If there is damage to the convolutes or any visible coolant leaks are detected, replace the complete bellows assembly. After 24 months or 5,000 operating hours, remove and inspect the bellows assembly regardless of its apparent external condition. If there is damage to the inside convolutes or if leaks are detected, replace the complete bellows assembly. When reinstalling the original or a replacement bellows assembly, all fasteners and locking devices are in place and tight on both flanges. Check the flame gap on Joints "G", "H", and "I" as described under No. 25, 31, 34  
*[SEE NOTE]*
33. [ ] Item No. 18 is the heat exchanger assembly. Its inlet flange is securely attached to the outlet of the water-cooled bellows. No gasket is installed and all fasteners and locking devices are in place and tight.  
*[WEEKLY]*
34. [ ] A 0.004" feeler gauge cannot be inserted into the **Joint "I"**.  
*[WEEKLY]*
35. [ ] Item No. 19 is the water injector. It is tightly installed into the pipe thread fitting on top of the inlet flange of the heat exchanger.  
*[WEEKLY]*
36. [ ] Item No. 20 is an exhaust pipe. Its inlet flange is securely attached to the outlet of the heat exchanger. No gasket is installed and all fasteners and locking devices are in place and tight.  
*[WEEKLY]*
37. [ ] A 0.004" feeler gauge cannot be inserted into **Joint "J"**.  
*[WEEKLY]*
38. [ ] Item No. 21 is an exhaust temperature sensor for the gauge in the operator's cab. It is securely installed into the exhaust elbow.  
*[WEEKLY]*



# DRY SYSTEMS TECHNOLOGIES®

[www.drysystemstech.com](http://www.drysystemstech.com) E-mail: [eng@drysystemstech.com](mailto:eng@drysystemstech.com)

## M389-003-01 \* POWER PACKAGE CHECKLIST \* Page 9

39. [ ] Item No. 22 is an optional flameproof port installed in the exhaust elbow for monitoring heat exchanger pressures when used in conjunction with a pressure differential gauge. If installed check that the flameproof port is tightly installed into the exhaust elbow. If the flameproof port is not installed, a pipe plug is securely installed into the port.  
[WEEKLY]
40. [ ] **Illustration No. 5** depicts the exhaust system components located from the heat exchanger to the filter housing. All components appear as depicted and there is no visible damage, cracks or dents on the components.  
[WEEKLY]

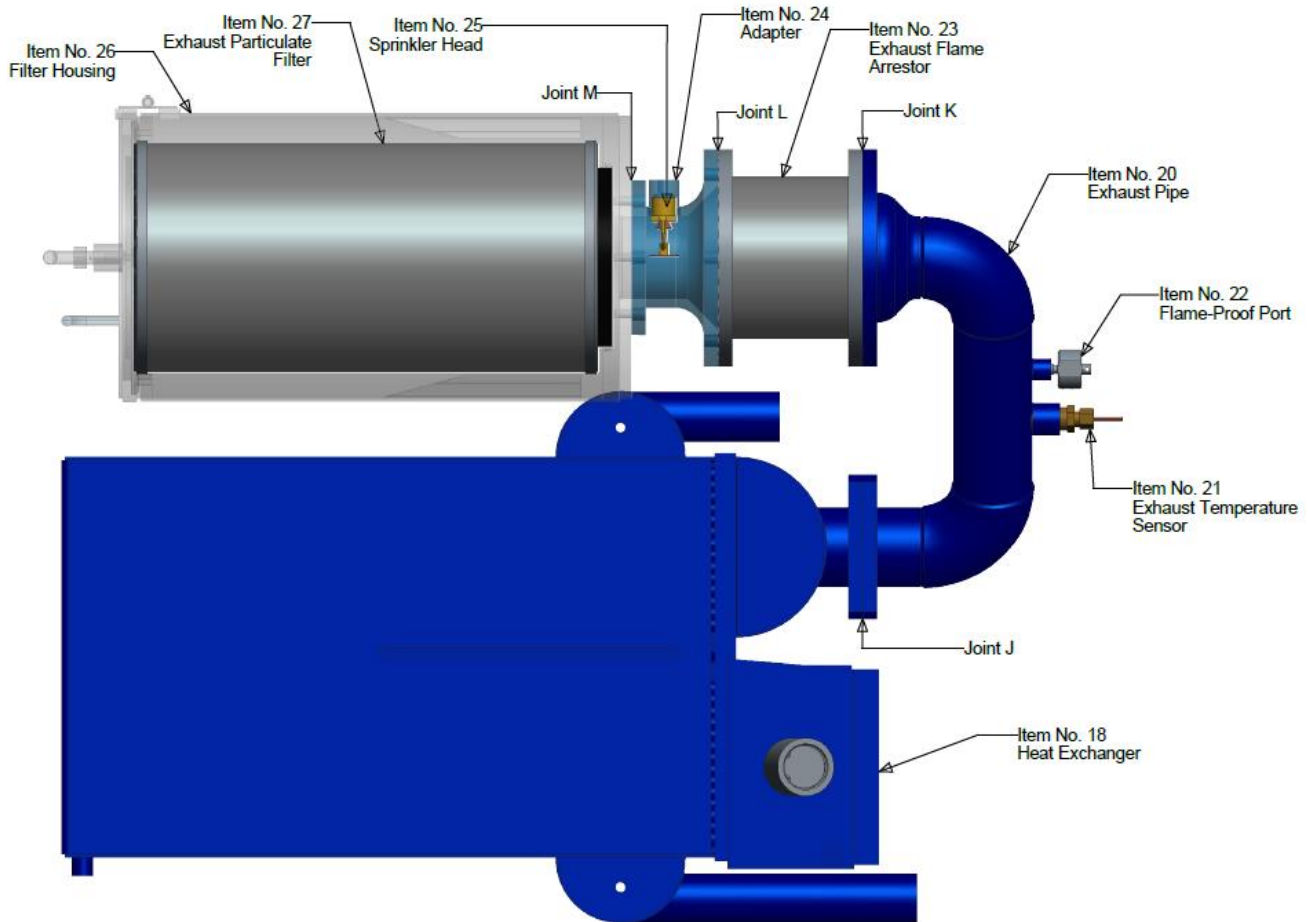

**Illustration No. 5: Exhaust Assembly "D"**

41. [ ] Item No. 23 is an exhaust flame arrester. It is securely attached to the outlet of the exhaust elbow and all fasteners and locking devices are in place and tight.  
[WEEKLY]

# DRY SYSTEMS TECHNOLOGIES®

[www.drysystemstech.com](http://www.drysystemstech.com) E-mail: [eng@drysystemstech.com](mailto:eng@drysystemstech.com)

## M389-003-01 \* POWER PACKAGE CHECKLIST \* Page 10

---

42. [ ]  
[12 MONTHS] Once every twelve months, remove the exhaust flame arrestor. The flame arrestor core consists of a 4" wide stainless-steel crimped ribbon element. There is no apparent damage and a 0.038" plug gauge will not pass through any of the triangular openings. The procedure is outlined in Illustration No. 8. When re-installing the exhaust flame arrestor assembly, all fasteners and locking devices are in place and tight on both flanges. Check the flame gap on **Joint "K"** as described under No. 43. No further check is necessary on **Joint "L"**.
43. [ ]  
[WEEKLY] A 0.004" feeler gauge cannot be inserted into **Joint "K"**.
44. [ ]  
[WEEKLY] Item No. 24 is an exhaust adapter placed between the exhaust flame arrestor and filter housing it is securely attached to the outlet of the flame arrestor and all fasteners and locking devices are in place and tight. No further check is necessary on **Joint "L"**.
45. [ ]  
[WEEKLY] Item No. 26 is an exhaust filter housing. It is securely attached to the exhaust adapter and all fasteners and locking devices are in place and tight. No gasket is used on this joint. No further check is necessary on **Joint "M"**.
46. [ ]  
[WEEKLY] Item No. 27 is an exhaust particulate filter element and must be marked **DRY SYSTEMS TECHNOLOGIES M70-417-01**.
47. [ ]  
[WEEKLY] Remove the exhaust particulate filter from the exhaust filter housing. Avoid direct contact with diesel soot. The use of protective gloves is recommended. Visually inspect the outlet side of the flame arrestor from the filter housing. There is no apparent damage to the crimped ribbon core of the exhaust flame arrestor. Visually inspect the exhaust particulate filter for damage or leaks. Reinstall the exhaust particulate filter into the exhaust filter housing, or replace it with a new DST exhaust particulate filter if necessary. **THE USE OF AFTERMARKET FILTERS WILL VOID ANY APPROVAL.**

## Fuel System

48. [ ]  
[WEEKLY]

**Illustration No. 6** depicts the fuel injection pump. The fuel injection rate adjustment mechanism and the engine governor setting are locked and sealed.

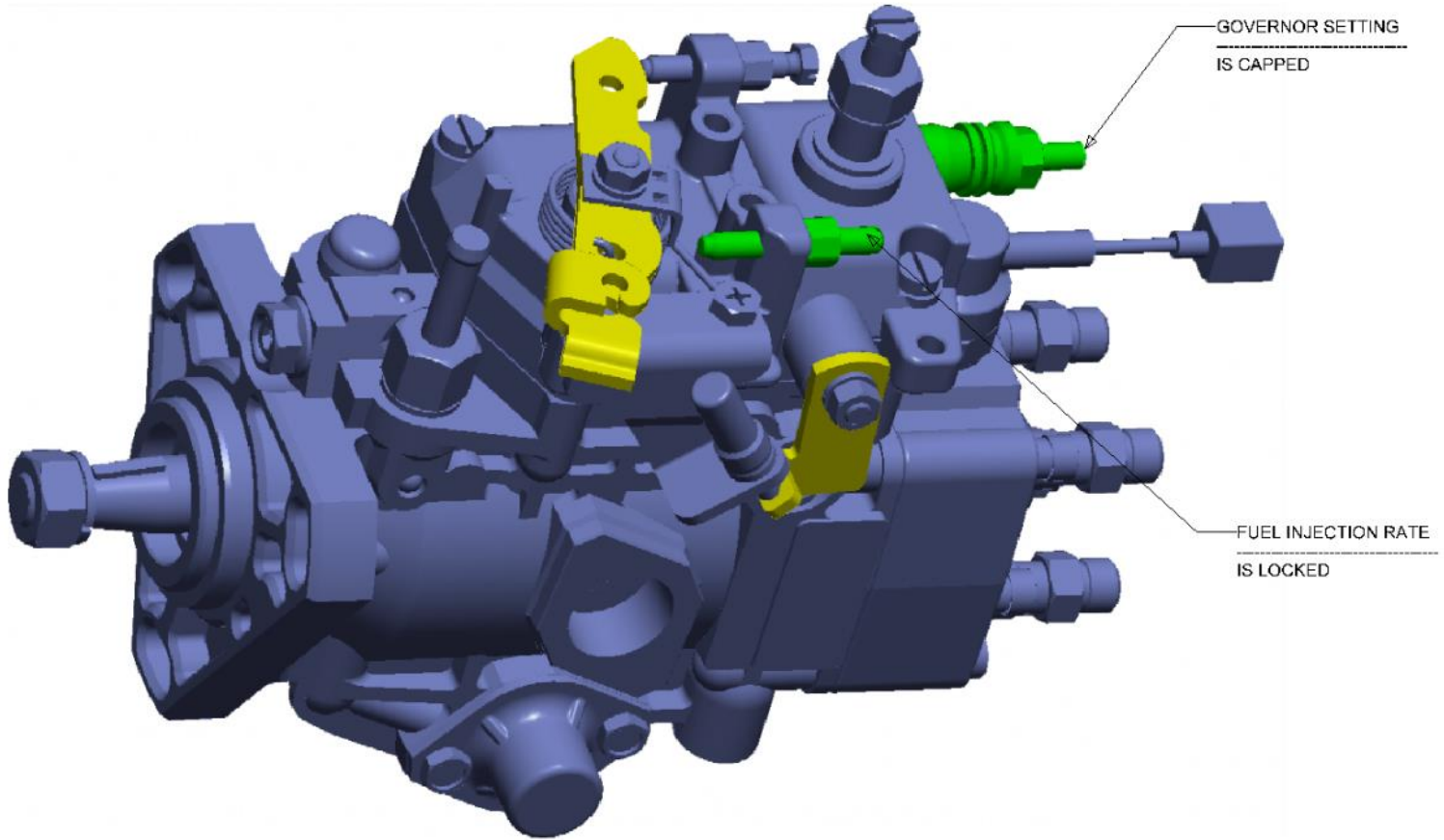

**Illustration No. 6: Fuel Injection Pump**

## **Safety Shutdown Devices**

49. [ ]  
[WEEKLY] Two temperature safety shutdown valves are part of the diesel power package. They are Item No.25 high exhaust temperature shutdown valve (sprinkler head) located on the exhaust filter housing inlet and Item No.28 high coolant temperature shutdown valve located in the coolant pipe connecting the engine and thermostat housing. Both valves are tightly installed and connected to the safety shutdown system. The locations are depicted on Illustrations No. 5 and No. 7.

50. [ ]  
[6 MONTHS] Item No. 28 is a high coolant temperature safety shutdown valve. It must be removed and be tested every 6 months as described below:

Remove the high coolant temperature shutdown valve and the integral well. Plug the opening for the high coolant temperature shutdown valve with a pipe plug while performing this test. Do not separate the valve from the well. Place the high coolant temperature shutdown valve into a 50%-50% mixture of water & ethylene glycol and heat the mixture with the engine running. **The high coolant temperature shutdown valve must shut down the engine before the mixture temperature exceeds 212°F.**

- a. Reinstall the high coolant temperature shutdown valve into the proper location. Make sure the valve is tightly installed and connected to the safety shutdown system.
- b. With the engine shut down, remove the DPM filter from the housing. Check Item No. 25 sprinkler head for damage, loose parts, scale coating, or corrosion. Verify the bulb color is blue. The model number is Tyco 3231, and the temperature rating is 286°F.

Replacement procedure for a blown sprinkler head:

Remove the DPM filter from the housing.

Remove the blown sprinkler head from inside the filter housing.

Install a new Tyco 3231 sprinkler head.

Place the DPM filter in the filter housing. Close and properly secure the filter housing.

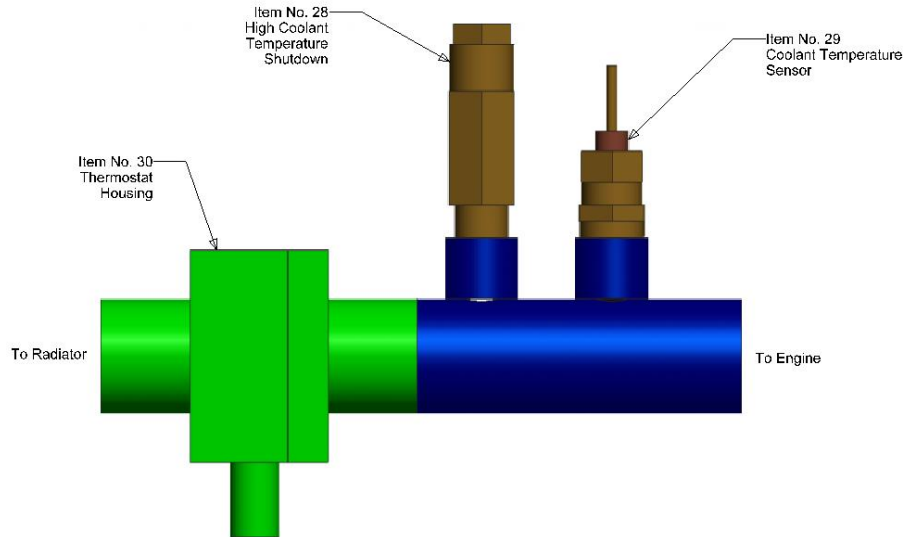

**Illustration No. 7: High Coolant Temperature Shutdown**

## **System Operations Check**

51. [ ] With the engine running at a moderate speed, activate the emergency shutdown valve. Upon activation, the intake air shutoff valve must operate immediately and **the engine must shut down within 15 seconds.**  
[WEEKLY]
52. [ ] If equipped with an optional tachometer, with the engine running, the transmission in neutral, all accessories dis-engaged, and the throttle pedal fully depressed, the engine speed indicated on the gauge in the operator's cab does not exceed 2,825 rpm.  
[WEEKLY]
53. [ ] Run the engine at torque stall. The total intake restriction shown on the gauge in the operator's cab must not exceed 32 inches H<sub>2</sub>O and the total exhaust restriction shown on the gauge in the operator's cab must not exceed 41 inches H<sub>2</sub>O.  
[WEEKLY]

## **Flame Arrestor Inspection Procedure** (Intake and Exhaust Flame Arrestor)

1. Remove the flame arrestor assembly.
2. Place the flame arrestor assembly on a flat surface with a contrasting background under the flame arrestor, such as brattice cloth or clean white cloth.
3. Adequate lighting is required. Cap lamp lighting is not sufficient.
4. Visually inspect each side of the flame arrestor for openings or spaces obviously greater than the triangular openings of the core.

# DRY SYSTEMS TECHNOLOGIES®

[www.drysystemstech.com](http://www.drysystemstech.com) E-mail: [eng@drysystemstech.com](mailto:eng@drysystemstech.com)

## M389-003-01 \* POWER PACKAGE CHECKLIST \* Page 14

5. Visually inspect each side of the core for places where the windings of the flame arrestor core appear to be separated such that gaps can be seen. If such gaps exist, they must be checked as following:
  - a.) The only measuring tool considered acceptable for performing this evaluation is a calibrated plug gauge. The plug gauge is to be mounted in a gauge holder and must project at least 1.00 inch out of the end.
  - b.) Grasp the gauge holder lightly between the index finger and the thumb. Place the wire tip at the point in question, making sure the plug gauge is vertical. Using only the weight of the gauge and holder, see if it will enter the apparent gap. Do not attempt to wiggle or push the gauge through the opening.
  - c.) If the plug gauge enters the opening, the flame arrestor core must not be used on permissible equipment.
6. Visually inspect the triangles in the flame arrestor core (both sides) for triangles that appear to be larger than the rest. If such conditions exist, these openings must be checked as previously described in section 5 a, b and c.
7. Finally, if the flame arrestor core passes all the above evaluations, a final check should be performed on at least 5 randomly selected triangles on each side of the core using the procedures described in section 5 a, b and c. In performing this check, the tip of the plug gauge must be placed against a specific triangular opening. If this special care is not taken, the evaluation will be invalid.

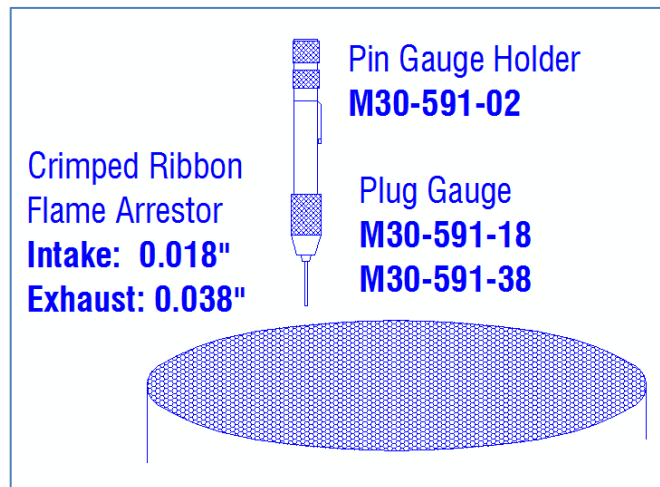

Illustration No. 8: Flame Arrestor Checking Procedure

**This Power Package Checklist contains 53 steps on 14 Pages with 8 Illustrations.**